

MGS F2 SP

3 hole mixer with side-spray

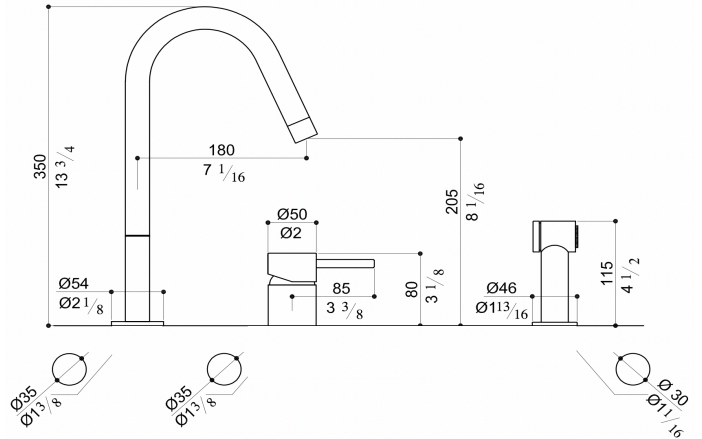

Specifications:

- **Marine Grade Stainless steel AISI316L**
- 100% lead free – fully recyclable
- The separate mixer can be freely positioned to the right or left of the spout, or also on the side of the sink
- The spout rotates 360°
- Areas of application: Indoor & outdoor
- Flow rate US: 1.75 GPM at 45 PSI in conformity with CalGreen and WaterSense requirements
- Flow rate EU: 12.0 L/Min at 3 Bar
- PVD finishes over brushed stainless steel

Available Finishes:



Stainless Steel



Black Steel



Titanium



Rose Gold



Gold

Engineered in Switzerland



Made in Italy