

DE Unterbauwaschtische  
EN Undercounter Washbasins  
FR Lavabos à encastrer  
NL Onder de toonbank wastafels

DE Montageanleitung  
EN Installation instruction  
FR Instructions de montage  
NL Montagehandleiding

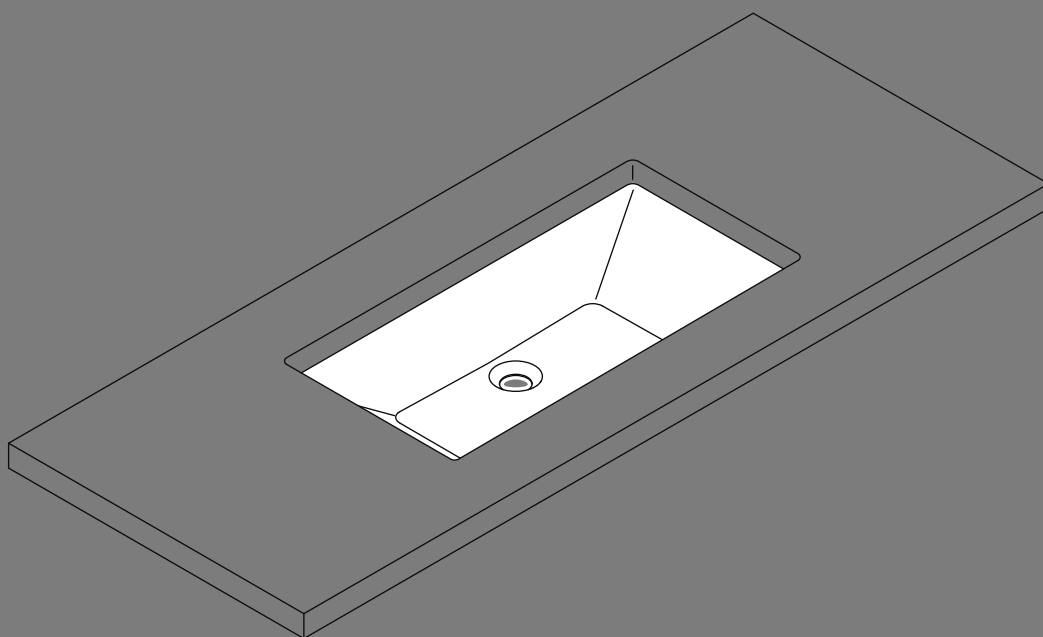

**BETTE**

### Symbolerklärung



Korrekte Montage



Falsche Montage



Verweis auf andere Produkte  
oder Dokumentationen



Optional



Ersatzteil



Klebmontage

### Allgemeine Hinweise

- Eine Gewährleistung in Bezug auf Sicherheit, Funktion und Unversehrtheit des Produkts kann nur geleistet werden, wenn die Hinweise in dieser Anleitung beachtet werden. Bei Missachtung können Körperverletzungen und Sachschäden auftreten. Für Schäden, die durch Nichtbeachtung der Anweisungen eintreten, haftet der Hersteller nicht.
- Um Montagefehler und Schäden am Produkt zu vermeiden, ist unbedingt nach den Anweisungen der Montageanleitung vorzugehen.
- Neben den Hinweisen in dieser Anleitung sind die allgemein gültigen Sicherheits- und Unfallvorschriften zu beachten.
- Das Produkt hat das Werk in sicherheitstechnisch einwandfreiem Zustand verlassen.
- Maßangaben in Millimeter (mm).
- Abbildungen nicht maßstabsgerecht.
- Technische Änderungen vorbehalten.

### Montagehinweise

- Die Montage darf nur durch einen Fachmann erfolgen.
- Der Bauuntergrund muss für die Aufnahme des Gewichtes geeignet sein.
- Um Beschädigungen am Produkt zu vermeiden, muss es mit größter Sorgfalt behandelt werden. Ringe und andere Gegenstände die das Produkt beschädigen können, müssen vor der Montage abgelegt werden.
- Schwere und sperrige Elemente müssen mit zwei Personen montiert werden.
- Starke Belastungen (z. B. Draufsetzen) können zu Beschädigungen an der Waschtischkonstruktion führen.
- Verwenden Sie zur Befestigung des Waschtisches auf der Trägerplatte handelsübliches Silikon oder Montagekleber.



Separate Dokumentationen (z. B. für Ablaufgarnituren) sind zu beachten.

**Key to symbols**

Correct installation



Incorrect installation



Cross reference to other products or documentation



Optional



Spare part



Adhesive mounting

**General advice**

- The function, safety and integrity of the product are only guaranteed if the instructions given in this manual are adhered to. Non-observance of the safety instructions could lead to bodily injury and damage to property.
- The manufacturer is not liable for damage resulting from non-observance of the instructions.
- To avoid installation errors and damage to the product, it is essential that the installation instructions are followed carefully.
- Besides the information given in this manual, please follow the relevant general safety and accident prevention regulations.
- This product left our factory in a condition complying with all the requirements of technical safety.
- Measurements are indicated in millimetres (mm).
- Figures are not true to scale
- Subject to technical modifications.

**Installation instructions**

- For installation by trained craftsmen only.
- The underlying structure must be suitable for bearing the weight involved.
- Handle this product with the utmost care to avoid damaging it. Rings and other objects that may damage the product must be removed before starting the installation work.
- Large, bulky or heavy items must be installed by two people.
- Heavy loads (e.g. sitting on it) can result in damage to the vanity unit structure.
- Use commercially available silicone or assembly adhesive to fix the washbasin to the support plate.



Separate documents (e. g. for drain sets) should be complied with.

## Explication des symboles



Montage correct



Montage incorrect



Référence aux autres produits ou documentations



En option



Pièce détachée



Montage adhésif

## Remarques générales

- Une garantie concernant la sécurité, la fonctionnalité et l'intégrité du produit peut uniquement être assurée si les consignes contenues dans cette notice d'utilisation sont respectées. Un non-respect de ces instructions peut entraîner des blessures corporelles ainsi que des dommages matériels. Le fabricant décline toute responsabilité pour les dommages dus à non-respect de ces consignes.
- Afin d'éviter toute erreur de montage et tout endommagement du produit, il est nécessaire de procéder au montage en tenant compte des instructions de cette notice.
- En plus des instructions de cette notice d'utilisation, il est nécessaire de respecter les règles générales en vigueur sur la sécurité et la prévention des accidents.
- Le produit a quitté l'usine dans un état irréprochable en matière de sécurité.
- Toutes les indications de mesure sont en millimètres (mm).
- Les illustrations ne sont pas à l'échelle.
- Sous réserve de modifications techniques.

## Instructions de montage

- Seul un personnel spécialisé est autorisé à effectuer le montage.
- Le support doit pouvoir supporter le poids de l'installation.
- Afin d'éviter tout endommagement sur le produit, il faut agir avec la plus grande précaution possible. Les bagues ou tout autre objet pouvant endommager le produit doivent être retirés avant de procéder au montage.
- Les éléments lourds et encombrants doivent être montés à l'aide de deux personnes.
- La structure du lavabo risque d'être endommagée en cas de fortes charges (par exemple, si l'on s'assoit dessus).
- Pour fixer le vasque sur la plaque de support, utilisez du silicone ou de la colle de montage disponible dans le commerce.



Veuillez observer les documentations séparées (par ex. pour les garnitures d'écoulement).

## Verklaring van de symbolen



Correcte montage



Onjuiste installatie



Verwijzing naar andere producten of documentatie



Optioneel



Reserveonderdeel



Zelfklevende montage

## Algemene informatie

- Veiligheid, correcte werking en onbeschadigd product kan alleen gegarandeerd worden wanneer de instructies in deze handleiding gevolgd worden. Bij niet-naleving kunnen lichaamsverwondingen en materiële schade optreden. Voor schade, die door niet-naleving van de aanwijzingen optreedt, aanvaardt de fabrikant geen aansprakelijkheid.
- Om montagefouten en schade aan het product te vermijden moeten de aanwijzingen uit de montagehandleiding stikt worden nageleefd.
- Naast de aanwijzingen in deze handleiding moeten de algemeen geldende veiligheids- en ongevalvoorschriften worden nageleefd.
- Het product heeft de fabriek in een veiligheidstechnisch perfecte staat verlaten.
- Afmetingen in millimeters (mm).
- Afbeeldingen zijn niet op schaal.
- Technische wijzigingen voorbehouden.

## Montage-instructies

- De montage mag alleen door een vakman gebeuren.
- De bouwondergrond moet geschikt zijn om het gewicht op te nemen.
- Om beschadigingen aan het product te vermijden moet het product zeer voorzichtig behandeld worden. Ringen en andere voorwerpen die het product kunnen beschadigen moeten voor de montage worden uitgedaan.
- Zware en onhandzame onderdelen moeten met twee personen worden gemonteerd.
- Sterke belastingen (bijv. erop zitten) kunnen leiden tot beschadigingen aan de constructie van de wastafel.
- Gebruik ter bevestiging van de wastafel op het topblad de in de handel verkrijgbare siliconen of montagelijm.



Afzonderlijke documentatie (bijv. voor afvoersets) moet in acht worden genomen.

BetteOne  
434 mm x 416 mm

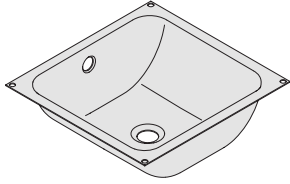

1 x BetteComodo  
574 mm x 380 mm

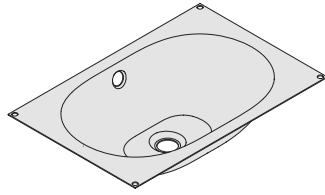

1 x BetteLoft  
740 mm x 386 mm

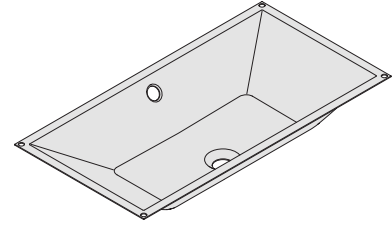

1 x

BetteOne  
587 mm x 408 mm

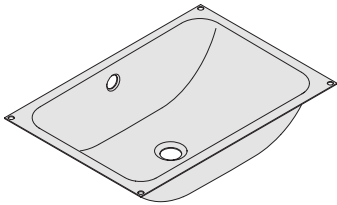

1 x BetteComodo  
774 mm x 380 mm

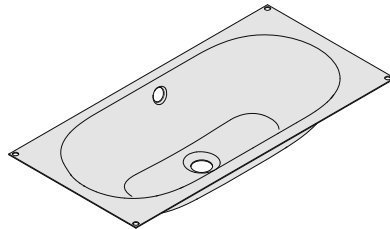

1 x

BetteOne  
767 mm x 408 mm

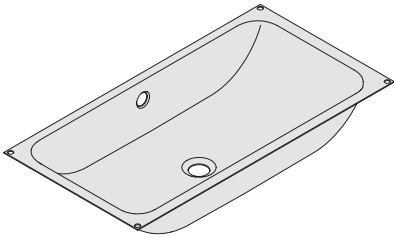

1 x

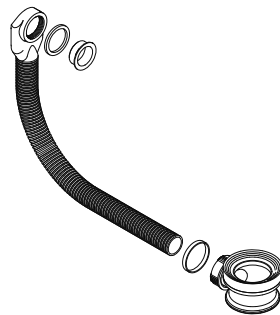

# Z0017993

1 x

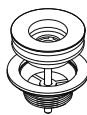

# B581

1 x

BetteComodo  
574 mm x 380 mm

1x

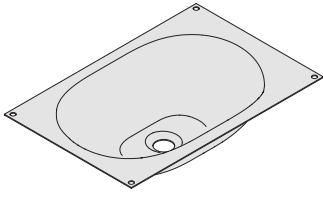

BetteLoft  
740 mm x 386 mm

1x

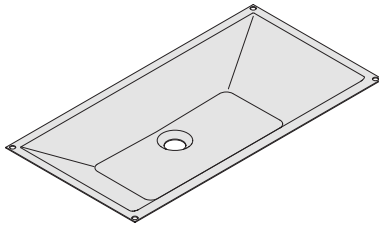

BetteBalance  
Ø 474 mm

1x

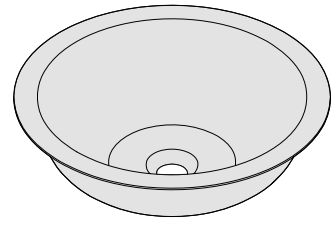

BetteComodo  
774 mm x 380 mm

1x

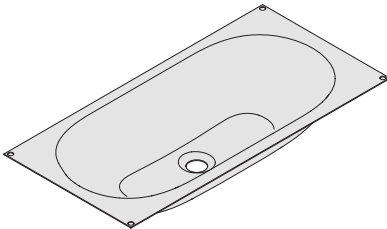

# Z0017920

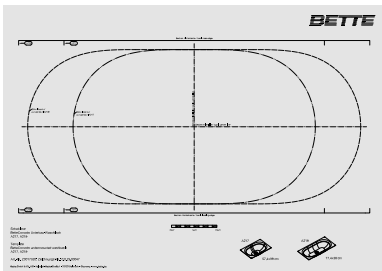

1x

# Z0017922

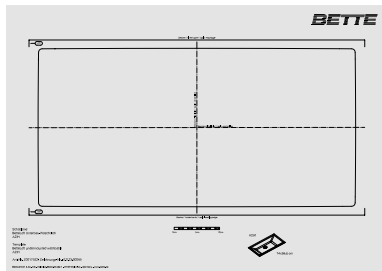

1x

# Z0020124

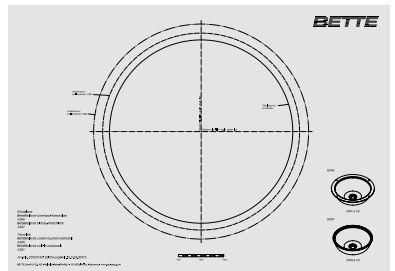

1x

# Z0015896  
1x



# B580

1x

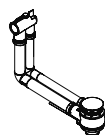

# B616

1x

**1a** BetteOne

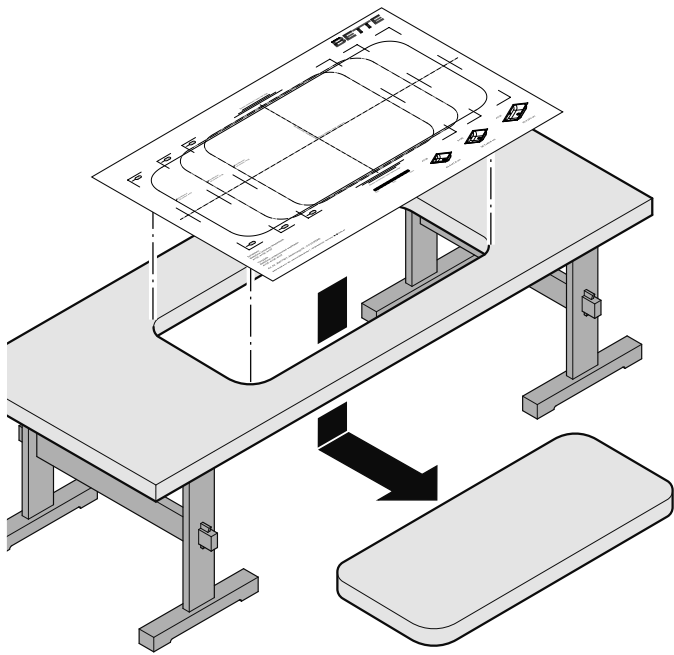

**1c** BetteLoft

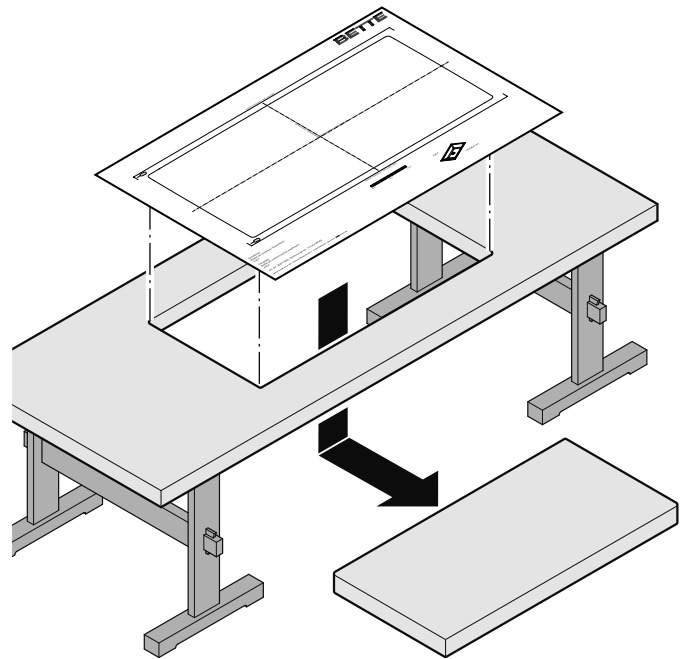

**1b** BetteComodo

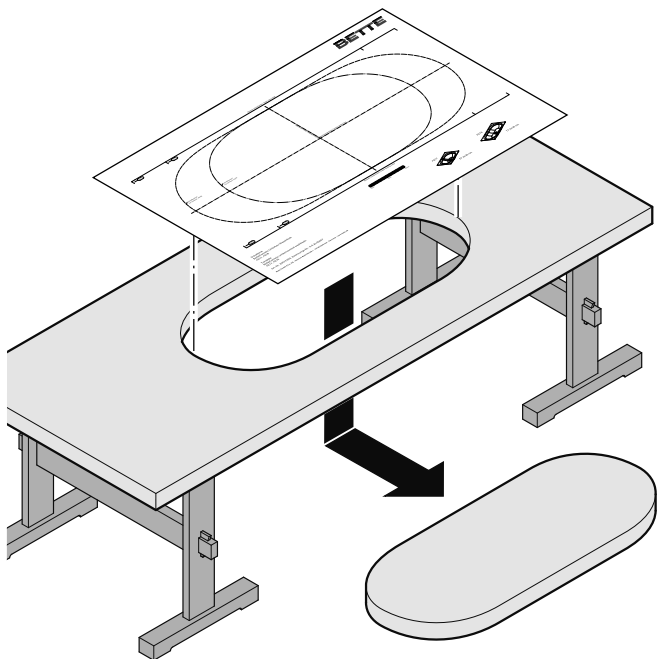

**1d** BetteBalance

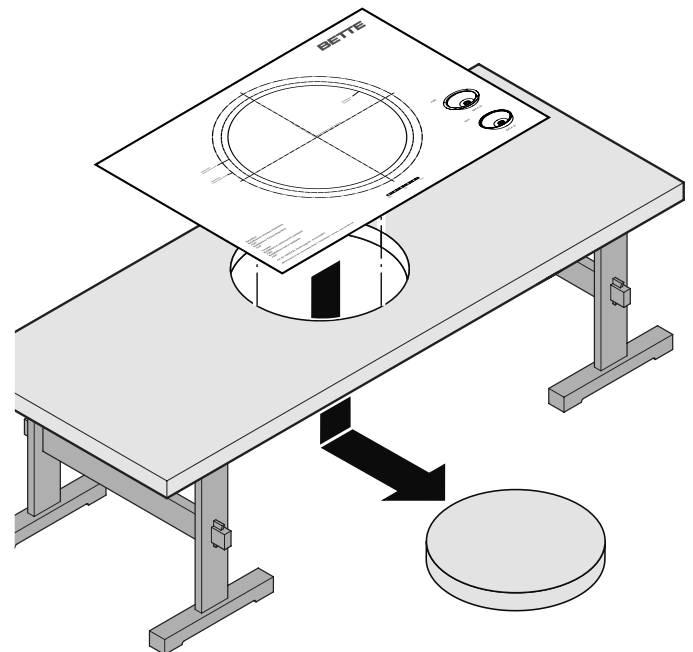



2

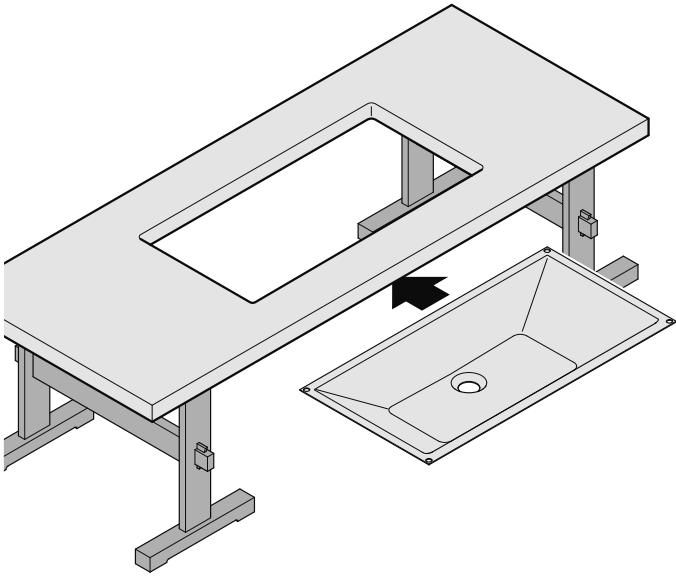

3

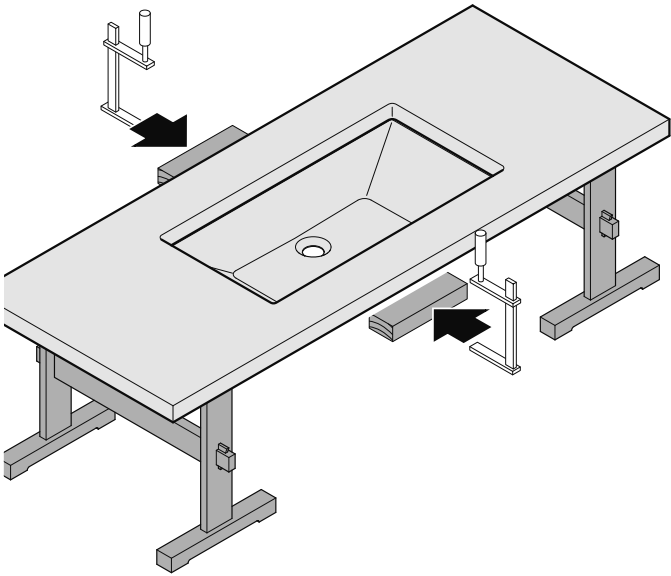

4

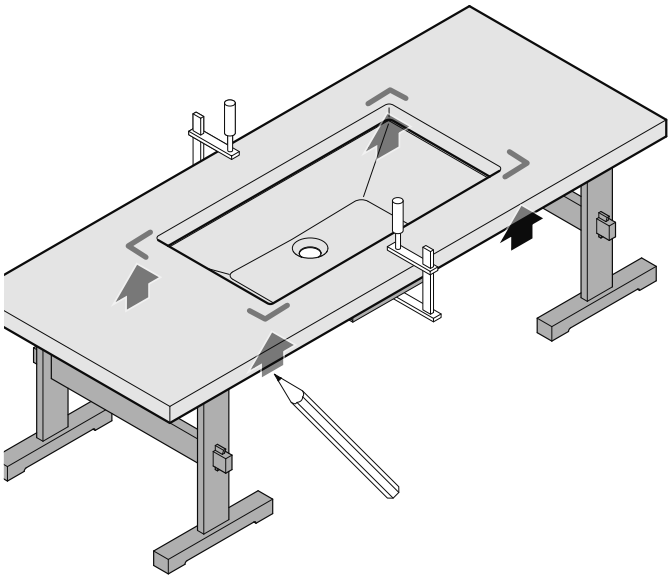

5

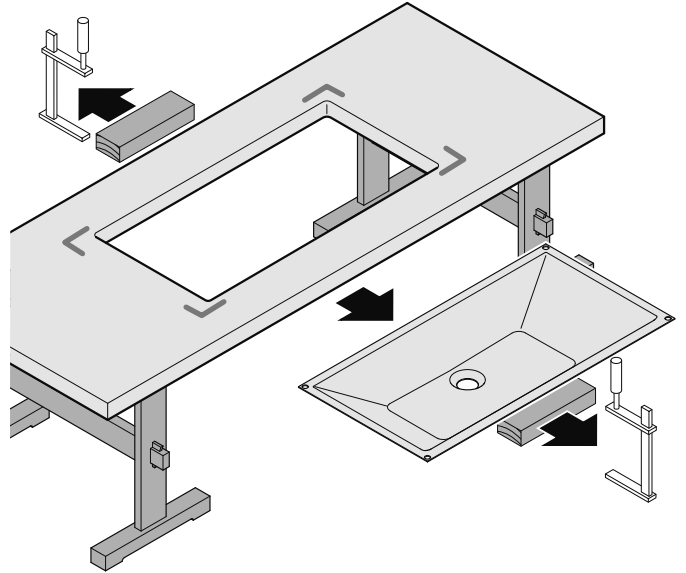

6

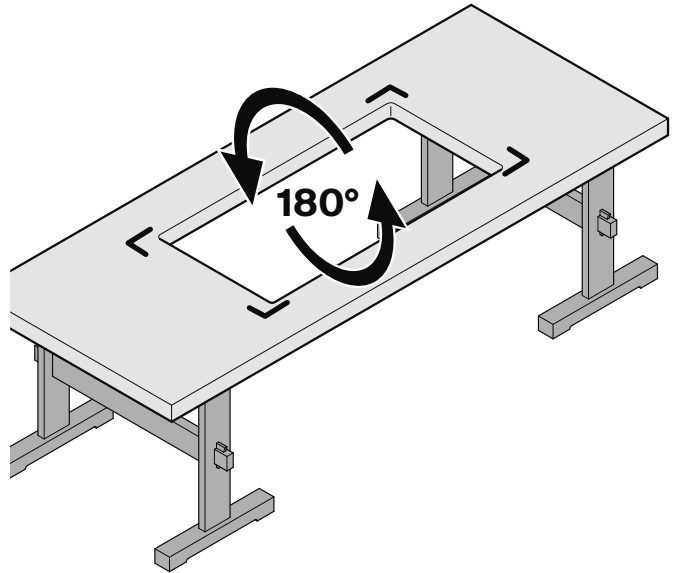

7

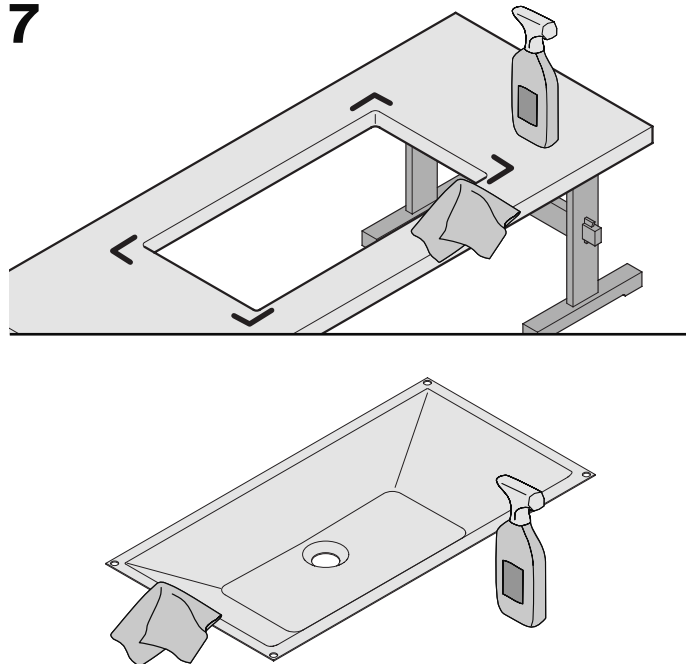

8

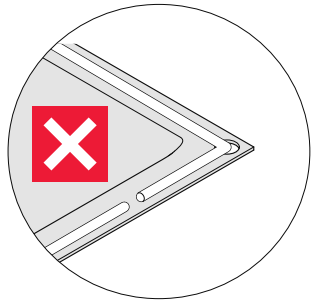
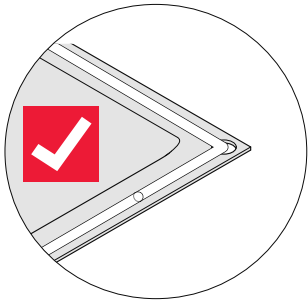
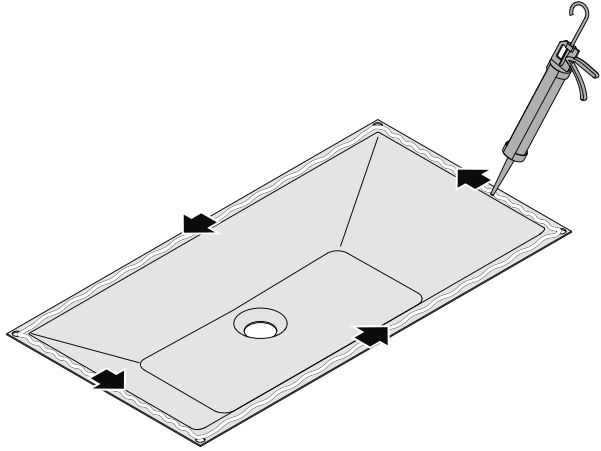
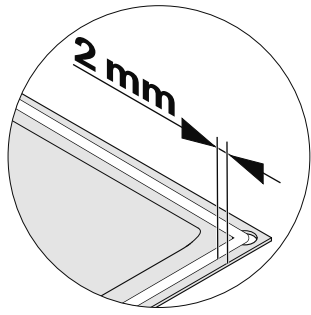

9

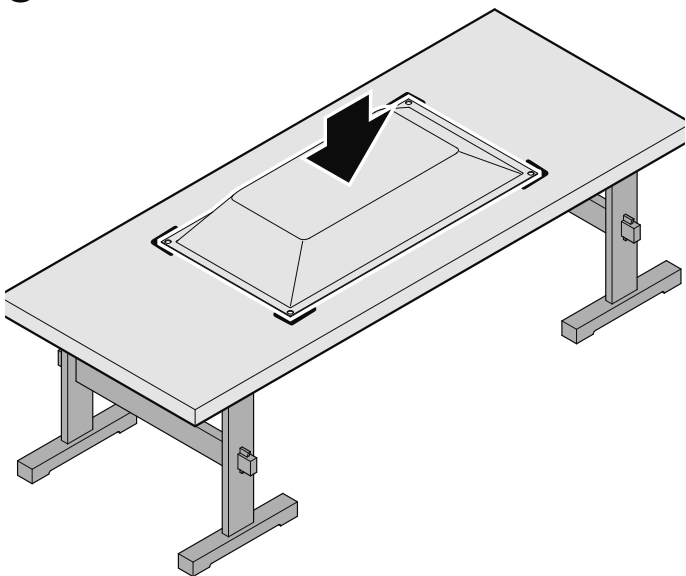

10

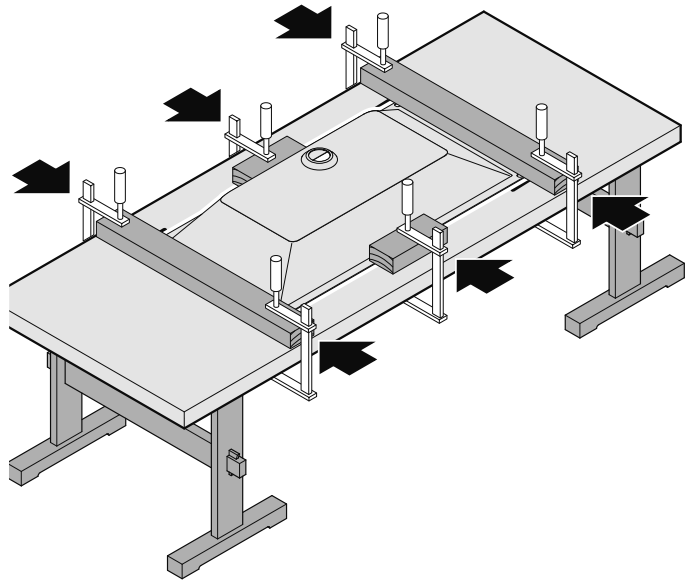

11

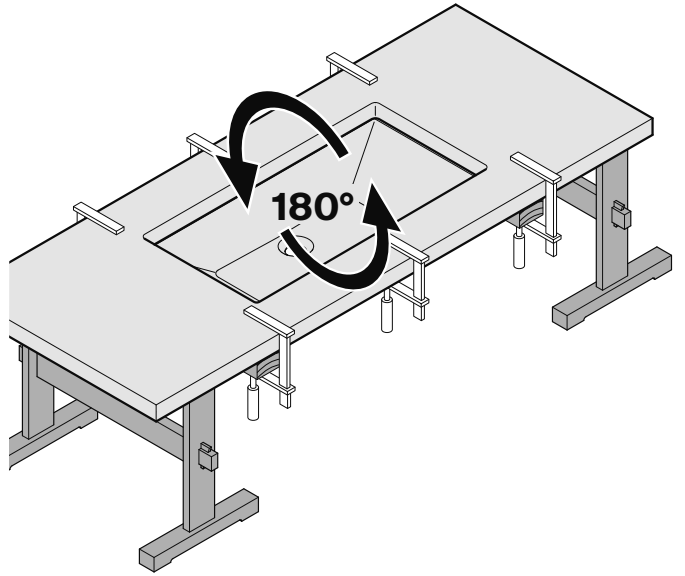

12

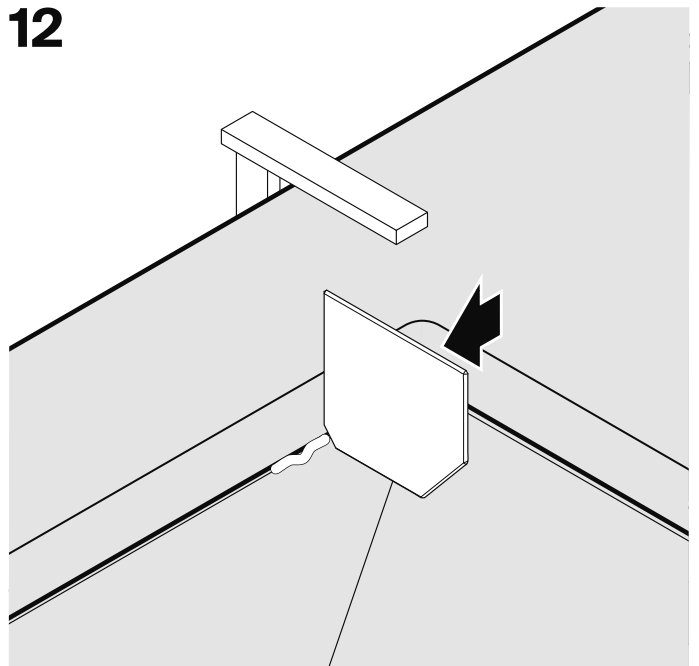

10

13

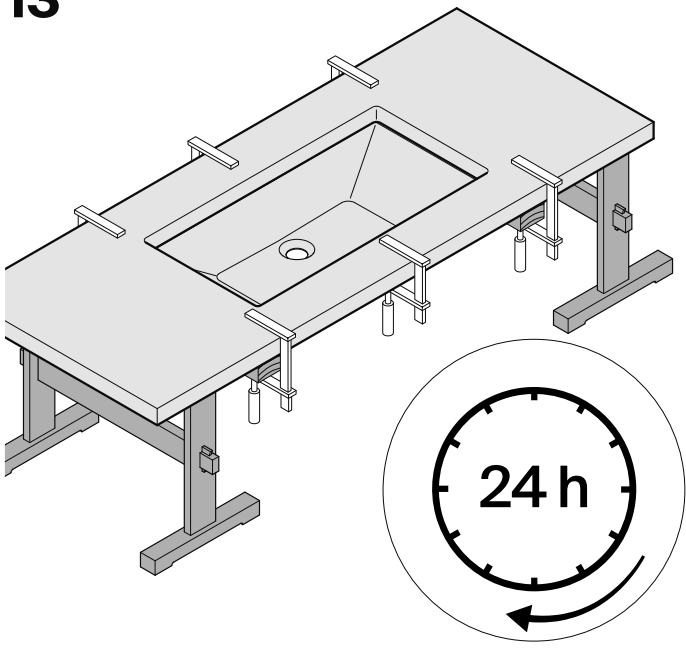

14

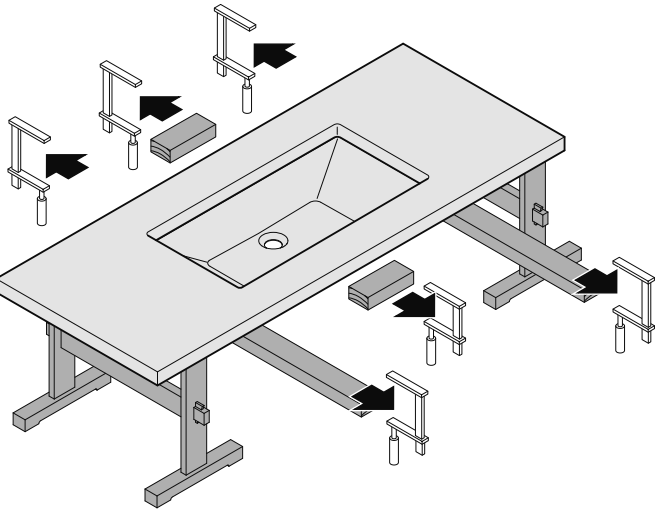

15

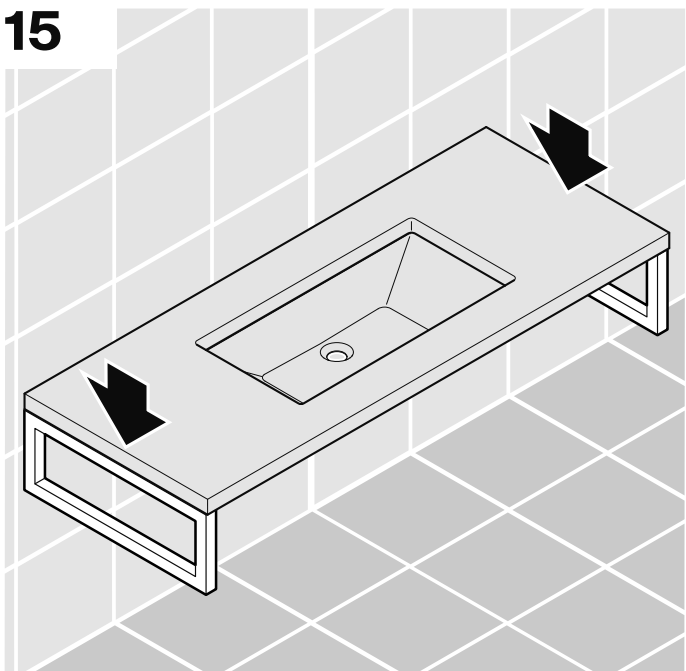

16

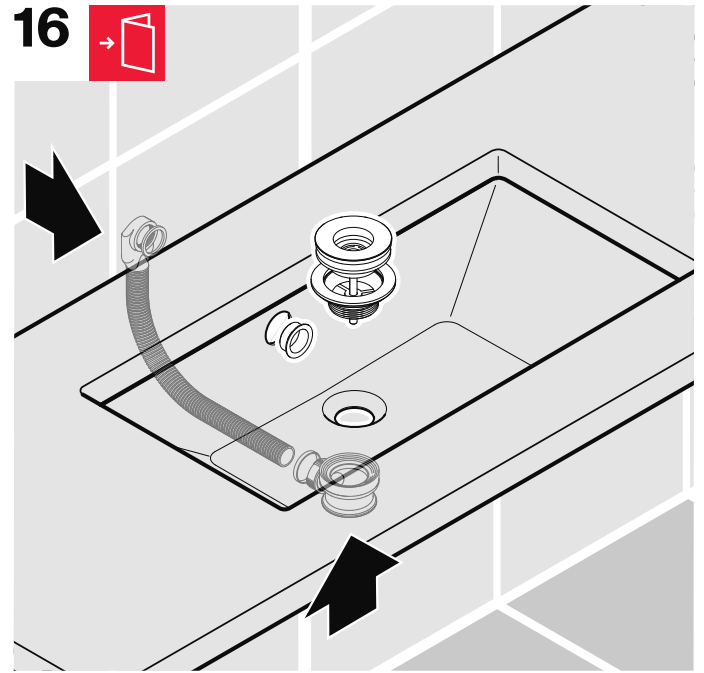

17

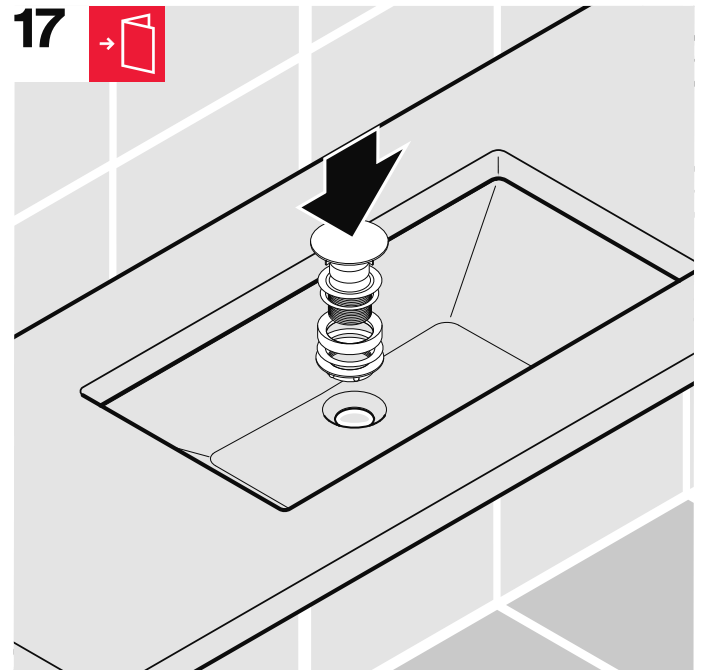

Bette GmbH & Co. KG  
Heinrich-Bette-Straße 1  
33129 Delbrück  
Germany  
T +49 5250 511-0  
F +49 5250 511-130  
info@bette.de

[www.my-bette.com](http://www.my-bette.com)

Rev. 3/ 03.2023 / Z0017935