

<b>DE</b>	Gebrauchsanleitung / Montageanleitung	2
<b>FR</b>	Mode d'emploi / Instructions de montage	2
<b>EN</b>	Instructions for use / Assembly instructions	3
<b>IT</b>	Istruzioni per l'uso / Istruzioni per Installazione	3
<b>ES</b>	Modo de empleo / Instrucciones de montaje	4
<b>NL</b>	Gebruiksaanwijzing / Handleiding	4
<b>DK</b>	Brugsanvisning / Monteringsvejledning	5
<b>PT</b>	Instruções para uso / Manual de Instalação	5
<b>PL</b>	Instrukcja obsługi / Instrukcja montażu	6
<b>CS</b>	Návod k použití / Montážní návod	6
<b>SK</b>	Návod na použitie / Montážny návod	7
<b>ZH</b>	用户手册 / 组装说明	7
<b>RU</b>	Руководство пользователя / Инструкция по монтажу	8
<b>FI</b>	Käyttöohje / Asennusohje	8
<b>SV</b>	Bruksanvisning / Monteringsanvisning	9
<b>LT</b>	Vartotojo instrukcija / Montavimo instrukcijos	9
<b>HR</b>	Upute za uporabu / Uputstva za instalaciju	10
<b>JP</b>	取扱説明書 / 施工説明書	10
<b>RO</b>	Manual de utilizare / Instrucțiuni de montare	11
<b>EL</b>	Οδηγίες χρήσης / Οδηγία συναρμολόγησης	11
<b>SL</b>	Navodilo za uporabo / Navodila za montažo	12
<b>ET</b>	Kasutusjuhend / Paigaldusjuhend	12
<b>LV</b>	Lietošanas pamācība / Montāžas instrukcija	13
<b>SR</b>	Uputstvo za upotrebu / Uputstvo za montažu	13
<b>NO</b>	Bruksanvisning / Montasjeveiledning	14
<b>BG</b>	Инструкция за употреба / Ръководство за монтаж	14
<b>SQ</b>	Udhëzuesi i përdorimit / Udhëzime rreth montimit	15
<b>AR</b>	دليل الاستخدام / تعليمات التجميع	15
<b>HU</b>	Használati útmutató / Szerelési útmutató	16
<b>TR</b>	Kullanım kılavuzu / Montaj kılavuzu	17

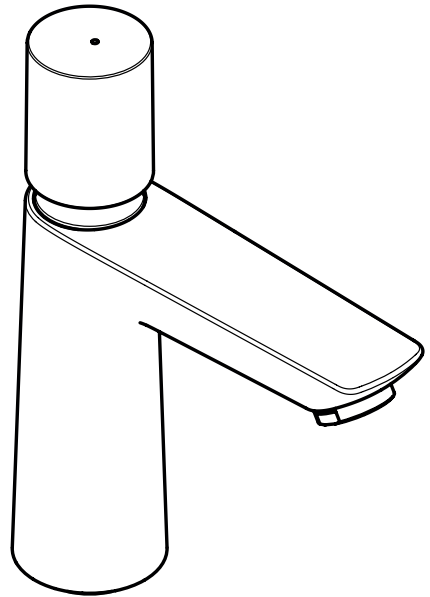

**Talis E**  
71719000



## Sicherheitshinweise

- Bei der Montage müssen zur Vermeidung von Quetsch- und Schnittverletzungen Handschuhe getragen werden.
- Das Produkt darf nur zu Bade-, Hygiene- und Körperreinigungszwecken eingesetzt werden.

## Montagehinweise

- Vor der Montage muss das Produkt auf Transportschäden untersucht werden. Nach dem Einbau werden keine Transport- oder Oberflächenschäden anerkannt.
- Die Leitungen und die Armatur müssen nach den gültigen Normen montiert, gespült und geprüft werden.
- Die in den Ländern jeweils gültigen Installationsrichtlinien sind einzuhalten.

## Technische Daten

### Armatur serienmäßig mit EcoSmart® (Durchflussbegrenzer)

Betriebsdruck:	max. 1 MPa
Empfohlener Betriebsdruck:	0,1 - 0,5 MPa
Prüfdruck:	1,6 MPa

(1 MPa = 10 bar = 147 PSI)

Das Produkt ist ausschließlich für Trinkwasser konzipiert!

## Symbolerklärung



Kein essigsäurehaltiges Silikon verwenden!



**Maße** (siehe Seite 22)



**Durchflussdiagramm** (siehe Seite 22)



**Serviceteile** (siehe Seite 23)

## Sonderzubehör

(nicht im Lieferumfang enthalten)



Serviceschlüssel #93913000 (siehe Seite 23)



**Reinigung** (siehe Seite 24)



**Bedienung** (siehe Seite 20)

Hansgrohe empfiehlt, morgens oder nach längeren Stagnationszeiten den ersten halben Liter nicht als Trinkwasser zu verwenden.



**Prüfzeichen** (siehe Seite 22)



## Consignes de sécurité

- Lors du montage, porter des gants de protection pour éviter toute blessure par écrasement ou coupure.
- Le produit ne doit servir qu'à se laver et à assurer l'hygiène corporelle.

## Instructions pour le montage

- Avant son montage, s'assurer que le produit n'a subi aucun dommage pendant le transport. Après le montage, tout dommage de transport ou de surface ne pourra pas être reconnu.
- Les conduites et la robinetterie doivent être montés, rincés et contrôlés selon les normes en vigueur.
- Les directives d'installation en vigueur dans le pays concerné doivent être respectées.

## Informations techniques

### Robinetterie équipée en série d'un EcoSmart® (limiteur de débit)

Pression de service autorisée:	max. 1 MPa
Pression de service conseillée:	0,1 - 0,5 MPa
Pression maximum de contrôle:	1,6 MPa

(1 MPa = 10 bar = 147 PSI)

Le produit est exclusivement conçu pour de l'eau potable!

## Description du symbole



Ne pas utiliser de silicone contenant de l'acide acétique!



**Dimensions** (voir pages 22)



**Diagramme du débit** (voir pages 22)



**Pièces détachées** (voir pages 23)

## Accessoires en option

(ne fait pas partie de la fourniture)



clé #93913000 (voir pages 23)



**Nettoyage** (voir pages 24)



**Instructions de service**

(voir pages 20)

Hansgrohe recommande de ne pas utiliser le premier demi-litre le matin ou après une période de stagnation prolongée.



**Classification acoustique et débit**  
(voir pages 22)

## Montage

(siehe Seite 18)

## Montage

(voir pages 18)



## Safety Notes

- △ Gloves should be worn during installation to prevent crushing and cutting injuries.
- △ The product may only be used for bathing, hygienic and body cleaning purposes.

## Installation Instructions

- Prior to installation, inspect the product for transport damages. After it has been installed, no transport or surface damage will be honoured.
- The pipes and the fixture must be installed, flushed and tested as per the applicable standards.
- The plumbing codes applicable in the respective countries must be observed.

## Technical Data

### This mixer series-produced with EcoSmart® (flow limiter)

Operating pressure:	max. 1 MPa
Recommended operating pressure:	0,1 - 0,5 MPa
Test pressure:	1,6 MPa

(1 MPa = 10 bar = 147 PSI)

The product is exclusively designed for drinking water!

## Symbol description

 Do not use silicone containing acetic acid!

 **Dimensions** (see page 22)

 **Flow diagram** (see page 22)

 **Spare parts** (see page 23)

**Special accessories** (order as an extra)

 service tool #93913000 (see page 23)

 **Cleaning** (see page 24)

 **Operation** (see page 20)

Hansgrohe recommends not to use as drinking water the first half liter of water drawn in the morning or after a prolonged period of non-use.

 **Test certificate** (see page 22)

## Indicazioni sulla sicurezza

- △ Durante il montaggio, per evitare ferite da schiacciamento e da taglio bisogna indossare guanti protettivi.
- △ Il prodotto deve essere utilizzato esclusivamente per fare il bagno e per l'igiene del corpo.

## Istruzioni per il montaggio

- Prima del montaggio è necessario controllare che non ci siano stati danni durante il trasporto. Una volta eseguito il montaggio, non verranno riconosciuti eventuali danni di trasporto o delle superfici.
- Montare, lavare e controllare tubature e rubinetteria rispettando le norme correnti.
- Vanno rispettate le direttive di installazione nazionali vigenti nel rispettivo paese.

## Dati tecnici

### Questo miscelatore è dotato di serie del EcoSmart® (limitatore di flusso)

Pressione d'uso:	max. 1 MPa
Pressione d'uso consigliata:	0,1 - 0,5 MPa
Pressione di prova:	1,6 MPa

(1 MPa = 10 bar = 147 PSI)

Il prodotto è concepito esclusivamente per acqua potabile!

## Descrizione simbolo

 Non utilizzare silicone contenente acido acetico!

 **Ingombri** (vedi pagg. 22)

 **Diagramma flusso** (vedi pagg. 22)

 **Parti di ricambio** (vedi pagg. 23)

## Accessori speciali

(non contenuto nel volume di fornitura)

 chiave per manutenzione #93913000 (vedi pagg. 23)

 **Pulitura** (vedi pagg. 24)

 **Procedura** (vedi pagg. 20)

Hansgrohe raccomanda, di mattina oppure dopo lunghi tempi di stagnazione, di non utilizzare il primo mezzo litro come acqua potabile.

 **Segno di verifica** (vedi pagg. 22)

**Assembly**  
(see page 18) 

**Montaggio**  
(vedi pagg. 18) 



## Indicaciones de seguridad

- △ Durante el montaje deben utilizarse guantes para evitar heridas por aplastamiento o corte.
- △ El producto solo debe ser utilizado para fines de baño, higiene y limpieza corporal.

## Indicaciones para el montaje

- Antes del montaje se debe examinar el producto contra daños de transporte. Después de la instalación no se reconoce ningún daño de transporte o de superficie.
- Los conductos y la grifería deben montarse, lavarse y comprobarse según las normas vigentes.
- Es obligatorio el cumplimiento de las directrices de instalación vigentes en el país respectivo.

## Datos técnicos

### Grifo, desde fábrica equipado con EcoSmart® (limitador de caudal)

Presión en servicio:	max. 1 MPa
Presión recomendada en servicio:	0,1 - 0,5 MPa
Presión de prueba:	1,6 MPa (1 MPa = 10 bar = 147 PSI)

El producto ha sido concebido exclusivamente para agua potable.

## Descripción de símbolos



No utilizar silicona que contiene ácido acético!



**Dimensiones** (ver página 22)



**Diagrama de circulación**  
(ver página 22)



**Repuestos** (ver página 23)

## Opcional (no incluido en el suministro)



Llave para desmontar  
#93913000 (ver página 23)



**Limpiar** (ver página 24)



**Manejo** (ver página 20)

Hansgrohe recomienda no utilizar el primer medio litro como agua potable por las mañanas o tras un largo periodo de inactividad.



**Marca de verificación**  
(ver página 22)



## Veiligheidsinstructies

- △ Bij de montage moeten ter voorkoming van kniel- en snijwonden handschoenen worden gedragen.
- △ Het product mag alleen voor het wassen, hygiënische doeleinden en voor de lichaamsreiniging worden gebruikt.

## Montage-instructies

- Vóór de montage moet het product gecontroleerd worden op transportschade. Na de inbouw wordt geen transport- of oppervlakteschade meer aanvaard.
- De leidingen en armaturen moeten gemonteerd, gespoeld en gecontroleerd worden volgens de geldige normen.
- De in de overeenkomstige landen geldende installatierichtlijnen moeten nageleefd worden.

## Technische gegevens

### Armatuur standaard met EcoSmart® (doorstroombegrenzer)

Werkdruk: max.	max. 1 MPa
Aanbevolen werkdruk:	0,1 - 0,5 MPa
Getest bij:	1,6 MPa (1 MPa = 10 bar = 147 PSI)

Het product is uitsluitend ontworpen voor drinkwater!

## Symboolbeschrijving



Gebruik geen zuurhoudende silicone!



**Maten** (zie blz. 22)



**Doorstroomdiagram** (zie blz. 22)



**Service onderdelen** (zie blz. 23)

## Toebehoren

(behoort niet tot het leveringspakket)



Servicesleutel #93913000 (zie blz. 23)



**Reinigen** (zie blz. 24)



**Bediening** (zie blz. 20)

Hansgrohe raadt aan om 's morgens na langere stagnatietijden de eerste halve liter niet als drinkwater te gebruiken.



**Keurmerk** (zie blz. 22)



## Sikkerhedsanvisninger

- △ Ved monteringen skal der bruges handsker for at undgå kvæstelser og snitsår.
- △ Produktet må kun bruges til bade-, hygiejne og kropsrengøringsformål.

## Monteringsanvisninger

- Før monteringen skal produktet kontrolleres for transportskader. Efter monteringen godkendes transportskader eller skader på overfladen ikke længere.
- Ledningerne og armaturerne skal monteres, skylles og kontrolleres iht. de gældende standarder.
- Installationsbestemmelserne, der gælder i det enkelte land, skal overholdes.

## Tekniske data

### Armaturet er forsynet med EcoSmart® (gennemstrømningsbegrænser)

Driftstryk:	max. 1 MPa
Anbefalet driftstryk:	0,1 - 0,5 MPa
Prøvetryk:	1,6 MPa
	(1 MPa = 10 bar = 147 PSI)

Produktet er udelukkende beregnet til drikkevand!

## Symbolbeskrivelse



Der må ikke benyttes eddikesyreholdig silikone!



**Målene** (se s. 22)



**Gennemstrømningsdiagram**  
(se s. 22)



**Reservedele** (se s. 23)

## Specialtilbehør (ikke med i leveringsomfang)



Monteringsnøgle #93913000 (se s. 23)



**Rengøring** (se s. 24)



**Brugsanvisning** (se s. 20)

Hansgrohe anbefaler at den første halve liter om morgenen eller efter længere stagneringstider ikke anvendes som drikkevand.



**Godkendelse** (se s. 22)

## Avisos de segurança

- △ Durante a montagem devem ser utilizadas luvas de protecção, de modo a evitar ferimentos resultantes de entalamentos e de cortes.
- △ O produto só pode ser utilizado para fins de higiene pessoal.

## Avisos de montagem

- Antes da montagem deve-se controlar o produto relativamente a danos de transporte. Após a montagem não são aceites quaisquer danos de transporte ou de superfície.
- As tubagens e a torneira têm que ser montadas, enxaguadas e verificadas de acordo com as normas em vigor.
- A prescrições de instalação válidas nos respetivos países devem ser respeitadas.

## Dados Técnicos

### Misturadoras produzidas em série com EcoSmart® (limitador de caudal)

Pressão de funcionamento:	max. 1 MPa
Pressão de func. recomendada:	0,1 - 0,5 MPa
Pressão testada:	1,6 MPa
	(1 MPa = 10 bar = 147 PSI)

Este produto foi única e exclusivamente concebido para água potável!

## Descrição do símbolo



Não utilizar silicone que contenha ácido acético!



**Medidas** (ver página 22)



**Fluxograma** (ver página 22)



**Peças de substituição**  
(ver página 23)

## Acessórios especiais

(não incluído no volume de fornecimento)



chave especial #93913000 (ver página 23)



**Limpeza** (ver página 24)



**Funcionamento** (ver página 20)

A Hansgrohe recomenda a não utilização do primeiro meio litro de água, de manhã ou após longas paragens, para fins de consumo.



**Marca de controlo** (ver página 22)

## Montering

(se s. 18) 

## Montagem

(ver página 18) 



## Wskazówki bezpieczeństwa

- △ Aby uniknąć zranień na skutek zgniecenia lub przecięcia, podczas montażu należy nosić rękawice ochronne.
- △ Produkt może być używany tylko do kąpieli, higieny i czyszczenia ciała.

## Wskazówki montażowe

- Przed montażem należy skontrolować produkt pod kątem szkód transportowych. Po montażu nie widać żadnych szkód transportowych ani szkód na powierzchni.
- Przewody i armatura muszą być montowane, płukane i kontrolowane według obowiązujących norm.
- Należy przestrzegać wytycznych instalacyjnych obowiązujących w danym kraju.

## Dane techniczne

### Armatura produkowana seryjnie z funkcją EcoSmart® (ogranicznik przepływu)

Ciśnienie robocze:	maks. 1 MPa
Zalecane ciśnienie robocze:	0,1 - 0,5 MPa
Ciśnienie próbne:	1,6 MPa

(1 MPa = 10 bar = 147 PSI)

Produkt przeznaczony wyłącznie do wody pitnej!

## Opis symbolu



Nie stosować silikonów zawierających kwas octowy!



**Wymiary** (patrz strona 22)



**Schemat przepływu**  
(patrz strona 22)



**Części serwisowe** (patrz strona 23)

## Wyposażenie specjalne

(Nie jest częścią dostawy)



Klucza montażowego  
#93913000 (patrz strona 23)



**Czyszczenie** (patrz strona 24)



**Obsługa** (patrz strona 20)

Hansgrohe zaleca, by z rana lub po dłuższym czasie niekorzystania, pierwsze pół litra wody nie używać jako wody pitnej.



**Znak jakości** (patrz strona 22)



## Bezpečnostní pokyny

- △ Pro zabránění řezným zraněním a pohmožděním je nutné při montáži nosit rukavice.
- △ Produkt smí být používán pouze ke koupání a za účelem tělesné hygieny.

## Pokyny k montáži

- Před montáží je třeba produkt zkontrolovat, zda nebyl při transportu poškozen. Po zabudování nebudou uznány žádné škody způsobené transportem nebo poškození povrchu.
- Vedení a armatura musí být namontovány, propláchnuty a otestovány podle platných norem.
- Je třeba dodržovat montážní pravidla platné v dané zemi.

## Technické údaje

### Armatura je sériově vybavena zařízením

#### EcoSmart® (omezovač průtoku)

Provozní tlak:	max. 1 MPa
Doporučený provozní tlak:	0,1 - 0,5 MPa
Zkušební tlak:	1,6 MPa

(1 MPa = 10 bar = 147 PSI)

Výrobky Hansgrohe jsou vhodné pro přímý kontakt s pitnou vodou.

## Popis symbolů



Nepoužívat silikon s obsahem kyseliny octové!



**Rozměry** (viz strona 22)



**Diagram průtoku** (viz strona 22)



**Servisní díly** (viz strona 23)

## Zvláštní příslušenství

(není součástí dodávky)



Servisní klíč #93913000 (viz strona 23)



**Čištění** (viz strona 24)



**Ovládání** (viz strona 20)

Hansgrohe doporučuje ráno nebo po delších přestávkách nepoužívat prvního půl litru jako pitnou vodu.



**Zkušební značka** (viz strona 22)

## Montaż

(patrz strona 18)

## Montáž

(viz strona 18)



## **Bezpečnostné pokyny**

- △ Pri montáži musíte nosiť rukavice, aby ste predišli pomliaždeninám a rezným poraneniam.
- △ Produkt sa smie používať len na kúpanie a telesnú hygienu.

## **Pokyny pre montáž**

- Pred montážou musíte produkt skontrolovať, či nebol počas transportu poškodený. Po zabudovaní nebudú uznané žiadne škody spôsobené transportom alebo poškodenia povrchu.
- Potrubia a vybavenie musia byť namontované, prepláchnuté a vybavené v platnom normami.
- Je potrebné dodržiavať smernice o inštalácii, ktoré sú práve teraz platné v krajinách.

## **Technické údaje**

### **Armatúra je sériovo vybavená zariadením EcoSmart® (obmedzovač prietoku)**

Prevádzkový tlak:	max. 1 MPa
Doporučený prevádzkový tlak:	0,1 - 0,5 MPa
Skúšobný tlak:	1,6 MPa

(1 MPa = 10 bar = 147 PSI)

Výrobok je koncipovaný výhradne pre pitnú vodu!

## **Popis symbolov**

 Nepoužívať silikón s obsahom kyseliny octovej!

 **Rozmery** (viď strana 22)

 **Diagram prietoku** (viď strana 22)

 **Servisné diely** (viď strana 23)

## **Zvláštne príslušenstvo**

(nie je súčasťou dodávky)

 Servisný kľúč #93913000 (viď strana 23)

 **Čistenie** (viď strana 24)

 **Obsluha** (viď strana 20)

Hansgrohe odporúča ráno a po dlhších dobách odstavky nepoužiť prvého pol litra vody ako pitnú vodu.

 **Osvedčenie o skúške**  
(viď strana 22)

## **安全技巧**

- △ 装配时为避免挤压和切割受伤，必须戴上手套。
- △ 本产品只允许作为洗浴、卫生和洁身之用。

## **安装提示**

- 安装前必须检查产品是否受到运输损害。安装后将不认可运输损害或表面损伤。
- 管道和阀门必须根据通用标准进行安装、冲洗和检查。
- 请遵守当地国家现行的安装规定。

## **技术参数**

本龙头配有 **EcoSmart® (流量限制器)**

工作压力:	最大 1 MPa
推荐工作压力:	0,1 - 0,5 MPa
测试压强:	1,6 MPa

(1 MPa = 10 bar = 147 PSI)

该产品专为饮用水设计！

## **符号说明**

 请勿使用含有乙酸的硅胶！

 **大小** (参见第页 22)

 **流量示意图** (参见第页 22)

 **备用零件** (参见第页 23)

## **选装附件 (不在供货范围内)**

 操作扳手 #93913000 (参见第页 23)

 **清洗** (参见第页 24)

 **操作** (参见第页 20)

汉斯格雅建议，清晨或在水流长时间停滞，前半升水不作饮用水使用。

 **检验标记** (参见第页 22)

## **Montáž**

(viď strana 18) 

## **安装**

(参见第页 18) 



## Указания по технике безопасности

- Во время монтажа следует надеть перчатки во избежание прищемления и порезов.
- Изделие разрешается использовать только в гигиенических целях: для принятия ванны и личной гигиены.

## Указания по монтажу

- Перед монтажом следует проверить изделие на предмет повреждений при перевозке. После монтажа претензии о возмещении ущерба за повреждения при перевозке или повреждения поверхностей не принимаются.
- Трубы и арматура должны быть установлены, промыты и проверены в соответствии с действующими нормами.
- Необходимо соблюдать требования по монтажу, действующие в соответствующих странах.

## Технические данные

### Смесители этой серии серийно оснащаются EcoSmart® (ограничителем потока воды)

Рабочее давление: не более 1 МПа  
 Рекомендуемое рабочее давление: 0,1 - 0,5 МПа  
 Давление: 1,6 МПа  
 (1 МПа = 10 bar = 147 PSI)

Изделие предназначено исключительно для питьевой воды!

## Описание символов



Не применяйте силикон, содержащий уксусную кислоту.



**Размеры** (см. стр. 22)



**Схема потока** (см. стр. 22)



**Комплект** (см. стр. 23)

## Специальные принадлежности

(не включено в объем поставки!)



Сервисный ключ #93913000 (см. стр. 23)



**Очистка** (см. стр. 24)



**Эксплуатация** (см. стр. 20)

Hansgrohe рекомендует по утрам либо после длительного перерыва в использовании не использовать первые поллитра воды для питья.



**Знак технического контроля**  
(см. стр. 22)



## Turvallisuusohjeet

- Asennuksessa on käytettävä käsineitä puristumien ja viiltojen aiheuttamien tapaturmien estämiseksi.
- Tuotetta saa käyttää ainoastaan kylpy-, hygienia- ja puhdistustarkoituksiin.

## Asennusohjeet

- Ennen asennusta on tarkastettava tuotteen mahdolliset kuljetusvahingot. Asennuksen jälkeen kuljetus- ja pintavaurioita ei hyväksytä.
- Putket ja hana on asennettava, huuhdeltava ja tarkastettava voimassa olevien standardien mukaisesti.
- Jokaisessa maassa on noudatettava siellä päteviä asennusohjeita.

## Tekniset tiedot

### Kaluste on vakiona varustettu EcoSmart® (virtauksenrajoittimella)

Käyttöpain: maks. 1 МПа  
 Suositeltu käyttöpain: 0,1 - 0,5 МПа  
 Koestuspaine: 1,6 МПа  
 (1 МПа = 10 bar = 147 PSI)

Tuote on suunniteltu käytettäväksi ainoastaan juomaveden kanssa!

## Merkin kuvaus



Älä käytä etikahappopitoista silikonial!



**Mitat** (katso sivu 22)



**Virtausdiagrammi** (katso sivu 22)



**Varaosat** (katso sivu 23)

## Erityisvaruste (ei kuulu toimitukseen)



Service-avain #93913000 (katso sivu 23)



**Puhdistus** (katso sivu 24)



**Käyttö** (katso sivu 20)

Hansgrohe suosittelee, että ensimmäistä puolta litraa ei käytetä juomavetenä aamuisin eikä silloin, kun laitetta ei ole käytetty pitkään aikaan.



**Koestusmerkki** (katso sivu 22)





## Säkerhetsanvisningar

- △ Handskar ska bäras under monteringsarbetet så att man kan undvika kläm- och skärskador.
- △ Produkten får bara användas till kroppshygien med bad och dusch.

## Monteringsanvisningar

- Det måste undersökas om produkten har transportskador innan den monteras. Efter monteringen accepteras inga transport- eller ytskiktsskador.
- Ledningarna och blandaren måste monteras, spolas igenom och kontrolleras enligt de gällande normerna.
- De installationsriktlinjer som gäller i länderna ska följas.

## Tekniska data

### Blandare seriemässigt med EcoSmart®

#### (flödeskontroll)

Driftstryck:	max. 1 MPa
Rek. driftstryck:	0,1 - 0,5 MPa
Tryck vid provtryckning:	1,6 MPa
	(1 MPa = 10 bar = 147 PSI)

Produkten är enbart avsedd för dricksvatten!

## Symbolförklaring



Använd inte silikon som innehåller ättiksyra!



**Måtten** (se sidan 22)



**Flödesschema** (se sidan 22)



**Reservdelar** (se sidan 23)

## Specialtillbehör (medföljer ej leveransen)



Service nyckel #93913000 (se sidan 23)



**Rengöring** (se sidan 24)



**Hantering** (se sidan 20)

Hansgrohe rekommenderar att den första halvlitern inte används som dricksvatten på morgonen eller efter längre perioder utan användning.



**Testsigill** (se sidan 22)



## Saugumo technikos nurodymai

- △ Apsaugai nuo užspaudimo ir įsijiovimo montavimo metu mūvėkite pirštines.
- △ Gaminys turi būti naudojamas tik maudymuisi, kūno higienai ir švarai palaikyti.

## Montavimo instrukcija

- Prieš montuojant būtina patikrinti, ar gaminys nebuvo pažeistas transportavimo metu. Sumontavus pretenzijos dėl transportavimo ir paviršiaus pažeidimų nepriimamos.
- Vamzdžiai ir sujungimai turi būti montuojami, plauunami ir tikrinami pagal galiojančias normas.
- Laikytis atitinkamoje šalyje galiojančių direktyvų dėl įrengimo.

## Techniniai duomenys

### Šios serijos maišytuvai turi EcoSmart® (vandens srauto ribotuvą)

Darbinis slėgis:	ne daugiau kaip 1 MPa
Rekomenduojamas slėgis:	0,1 - 0,5 MPa
Bandomasis slėgis:	1,6 MPa
	(1 MPa = 10 bar = 147 PSI)

Produktas skirtas tik geriamajam vandeniui!

## Simbolio aprašymas



Nenaudokite silikono, kurio sudėtyje yra acto rūgšties!



**Išmatavimai** (žr. psl. 22)



**Pralaidumo diagrama** (žr. psl. 22)



**Atsarginės dalys** (žr. psl. 23)

## Specialūs priedai (nėra pridedama)



Techninės priežiūros raktas #93913000 (žr. psl. 23)



**Valymas** (žr. psl. 24)



**Eksplotacija** (žr. psl. 20)

Naudojant po ilgesnės pertraukos, „Hansgrohe“ rekomenduoja pirmo pusės litro vandens nevartoti kaip geriamojo.



**Bandymo pažyma** (žr. psl. 22)

## Montering

(se sidan 18) 

## Montavimas

(žr. psl. 18) 



## Sigurnosne upute

- △ Prilikom montaže se radi sprječavanja prignječenja i posjekotina moraju nositi rukavice.
- △ Proizvod se smije primjenjivati samo za kupanje, tuširanje i osobnu higijenu.

## Upute za montažu

- Prije montaže mora se provjeriti je li proizvod oštećen prilikom transporta. Nakon ugradnje se ne priznaju nikakve reklamacije koje se odnose na površinska i transportna oštećenja.
- Cijevi i armatura moraju biti postavljeni, isprani i testirani prema važećim normama.
- Obvezno se moraju uvažiti propisi o instalacijama koji vrijede u dotičnoj zemlji.

## Tehnički podatci

### Armatura ima serijski ugrađen EcoSmart® (limitator protoka)

Najveći dopušteni tlak:	tlak 1 MPa
Preporučeni tlak:	0,1 - 0,5 MPa
Probni tlak:	1,6 MPa
	(1 MPa = 10 bar = 147 PSI)

Proizvod je koncipiran isključivo za pitku vodu!

## Opis simbola



Nemojte koristiti silikon koji sadrži octenu kiselinu!



**Mjere** (pogledaj stranicu 22)



**Dijagram protoka**  
(pogledaj stranicu 22)



**Rezervni dijelovi**  
(pogledaj stranicu 23)

## Posebni pribor (Nije sadržano u isporuci!)



Servisni odvijač  
#93913000 (pogledaj stranicu 23)



**Čišćenje** (pogledaj stranicu 24)



**Upotreba** (pogledaj stranicu 20)

Hansgrohe preporuča da ujutro ili nakon duljeg nekorisćenja prvih 1/2 litre vode ne upotrebljavate za piće.



**Oznaka testiranja**  
(pogledaj stranicu 22)



## 安全上の注意

- △ 施工の際は手を挟んだり怪我をしないように、手袋をはめてください。
- △ この製品は、体や手を洗う等の製品本来の目的以外には使用しないでください。

## 施工上の注意

- 製品の施工前に輸送でのダメージがないか確認してください。施工後のキズ等のお申し出はお断りさせて頂いています。
- 配管と水栓は、関連法規に従って施工、洗浄、および試験を行ってください。
- 施工行う地域に適用される関連法規をお守りください。

## 技術資料

### EcoSmart® (流量リミッター) 付きの水栓

使用圧力:	最大 1 MPa
推奨使用水圧:	0,1 - 0,5 MPa
耐圧試験圧力:	1,6 MPa
	(1 MPa = 10 bar = 147 PSI)

この製品は飲料水での使用が前提となっています (日本においては水道法に適合する飲料水)!

## アイコンの説明



酢酸系シリコンをご使用にならないでください!



**寸法** (次のページを参照 22)



**流量曲線図** (次のページを参照 22)



**スペアパーツ**  
(次のページを参照 23)

## スペシャルパーツ (別手配部品)



メンテナンス工具 #93913000  
(次のページを参照 23)



**お手入れ方法**  
(次のページを参照 24)



**使用方法** (次のページを参照 20)

ハンスグローエは、朝または長い間使用されなかった後に吐水する最初の0.5リットルは飲料水として使用しないことをお勧めします。



**認証について**  
(次のページを参照 22)

## Sastavljanje

(pogledaj stranicu 18)

## 施工方法

(次のページを参照 18)



## Instrucțiuni de siguranță

- Δ La montare utilizați mănuși pentru evitarea contuziunilor și tăierii mâinilor.
- Δ Produsul poate fi utilizat doar pentru spălarea, menținerea igienei și curățarea corpului.

## Instrucțiuni de montare

- Înainte de instalare verificați, dacă produsul prezintă deteriorări de transport. După instalare garanția nu acoperă deteriorările de transport și cele de suprafață.
- Conductele și bateriile trebuie montate, spălate și verificate conform normelor în vigoare.
- Respectați reglementările referitoare la instalare valabile în țara respectivă.

## Date tehnice

### Bateria este dotată în serie cu EcoSmart® (limitator de debit)

Presiune de funcționare:	max. 1 MPa
Presiune de funcționare recomandată:	0,1 - 0,5 MPa
Presiune de verificare:	1,6 MPa (1 MPa = 10 bar = 147 PSI)

Produsul este destinat exclusiv pentru apă potabilă.

## Descrierea simbolurilor

 Nu utilizați silicon cu conținut de acid acetic!

 **Dimensiuni** (vezi pag. 22)

 **Diagrama de debit** (vezi pag. 22)

 **Piese de schimb** (vezi pag. 23)

## Accesorii opționale

(nu este inclus în setul livrat)

 Cheie service #93913000 (vezi pag. 23)

 **Curățare** (vezi pag. 24)

 **Utilizare** (vezi pag. 20)

Hansgrohe vă recomandă, ca dimineața sau după perioade mai lungi de pauză să nu folosiți prima jumătate de litru de apă pentru băut.

 **Certificat de testare** (vezi pag. 22)

## Υποδειξεις ασφαλειας

- Δ Για να αποφύγετε τραυματισμούς κατά τη συναρμολόγηση πρέπει να φοράτε γάντια.
- Δ Το προϊόν επιτρέπεται να χρησιμοποιείται μόνο σαν μέσο λουτρού, υγιεινής και καθαρισμού του σώματος.

## Οδηγίες συναρμολόγησης

- Πριν τη συναρμολόγηση πρέπει να εξεταστεί το προϊόν για ζημιές μεταφοράς. Μετά την εγκατάσταση δεν αναγνωρίζονται ζημιές από τη μεταφορά ή επιφανειακές ζημιές.
- Οι σΛήνες και η μπαταρία πρέπει να τοποθετηθούν σύμφωνα με τα ισχύοντα πρότυπα, να τεθούν υπό πίεση και να δοκιμαστούν.
- Θα πρέπει να τηρούνται οι οδηγίες εγκατάστασης που ισχύουν σε κάθε κράτος.

## Τεχνικά Χαρακτηριστικά

### Μπαταρία μόνιμα εξοπλισμένη με EcoSmart® (μειωτής ροής)

Λειτουργία πίεσης:	έως 1 MPa
Συνιστώμενη λειτουργία πίεσης:	0,1 - 0,5 MPa
Πίεση ελέγχου:	1,6 MPa (1 MPa = 10 bar = 147 PSI)

Το προϊόν έχει σχεδιαστεί αποκλειστικά για πόσιμο νερό!.

## Περιγραφή συμβόλων

 Μην χρησιμοποιείτε σιλικόνη που περιέχει οξικό οξύ!

 **Διαστάσεις** (βλ. Σελίδα 22)

 **Διάγραμμα ροής** (βλ. Σελίδα 22)

 **Ανταλλακτικά** (βλ. Σελίδα 23)

**Ειδικά αξεσουάρ** (δεν περιλαμβάνεται στον παραδοτέο εξοπλισμό)

 Κλειδί για σέρβις #93913000 (βλ. Σελίδα 23)

 **Καθαρισμός** (βλ. Σελίδα 24)

 **Χειρισμός** (βλ. Σελίδα 20)

Η Hansgrohe συνιστά το πρΩι ή μετά από μεγάλα χρονικά διαστήματα αχρησίας να μην χρησιμοποιείτε το πρώτο μισό λίτρο νερό σαν πόσιμο.

 **Σήμα ελέγχου** (βλ. Σελίδα 22)

**Montare**  
(vezi pag. 18) 

**Συναρμολόγηση**  
(βλ. Σελίδα 18) 

**Varnostna opozorila**

- △ Pri montaži je treba nositi rokavice, da se prepreči poškodbe zaradi zmečkanja ali urezov.
- △ Ta izdelek se sme uporabljati le z namenom umivanja, vzdrževanja higiene in telesne nege.

**Navodila za montažo**

- Pred montažo je treba izdelek preveriti glede morebitnih transportnih poškodb. Po vgradnji transportne ali površinske poškodbe ne bodo več priznane.
- Cevi in armaturo je treba montirati, izprati in preveriti po veljavnih standardih.
- Upoštevati je treba pravilnike o inštalacijah, ki veljajo v posamezni državi.

**Tehnični podatki****Armaturo je serijsko opremljena z EcoSmart® (omejevalnikom pretoka)**

Delovni tlak:	maks. 1 MPa
Priporočeni delovni tlak:	0,1 - 0,5 MPa
Preskusni tlak:	1,6 MPa
	(1 MPa = 10 bar = 147 PSI)

Proizvod je zasnovan izključno za sanitarno vodo!

**Opis simbola**

Ne smete uporabiti silikona, ki vsebuje ocetno kislino!



**Mere** (glejte stran 22)



**Diagram pretoka** (glejte stran 22)



**Rezervni deli** (glejte stran 23)

**Poseben pribor** (Ni vključeno)

Servisni ključ #93913000 (glejte stran 23)



**Čiščenje** (glejte stran 24)



**Upravljanje** (glejte stran 20)

Hansgrohe priporoča, da zjutraj ali po daljšem času stagnacije prvega pol litra vode ne uporabite kot pitno vodo.



**Preskusni znak** (glejte stran 22)

**Ohutusjuhid**

- △ Kandke paigaldamisel muljumis- ja löikevigestuste vältitsemeks kindaid.
- △ Toodet tohib kasutada ainult pesemis-, higienni- ja kehapuhastamisesmärki.

**Paigaldamisjuhid**

- Enne paigaldamist tuleb toodet kontrollida transportdikahjustuste osas. Pärast paigaldamist ei tunnustata enam transporti- või pinnakahjustuste kaebuseid.
- Voolikute ja segisti paigaldamisel, loputamisel ja kontrollimisel tuleb lähtuda kehtivast normatiividest.
- Vastavas riigis kehtivaid paigalduseeskirju tuleb järgida.

**Tehnilised andmed****Segistisari on toodetud koos EcoSmart® (veehulgapiirajaga)**

Töörõhk	maks. 1 MPa
Soovitav töörõhk:	0,1 - 0,5 MPa
Kontrollsurve:	1,6 MPa
	(1 MPa = 10 bar = 147 PSI)

Toode on ette nähtud eranditult joogivee jaoks!

**Sümbolite kirjeldus**

Ärge kasutage äädikhapet sisaldavat silikoonil!



**Mõõtude** (vt lk 22)



**Läbivooludiagramm** (vt lk 22)



**Varuosad** (vt lk 23)

**Spetsialne lisavarustus**

(ei sisaldu komplektis)



Hooldusvõti #93913000 (vt lk 23)



**Puhastamine** (vt lk 24)



**Kasutamine** (vt lk 20)

Hansgrohe soovib mitte kasutada esimest poolt liitrit hommikuti või pärast pikemat seisakuaega joogiveena.



**Kontrollsertifikaat** (vt lk 22)

**Montaža**

(glejte stran 18)

**Paigaldamine**

(vt lk 18)



## Drošības norādes

- △ Montāžas laikā, lai izvairītos no saspiedumiem un iegriezumiem, nepieciešams nēsāt cimdus.
- △ Šo produktu drīkst izmantot tikai, lai mazgātos, higiēnai un ķermeņa tīrīšanai.

## Norādījumi montāžai

- Pirms montāžas nepieciešams pārbaudīt, vai produktam transportēšanas laikā nav radušies bojājumi. Pēc iebūvēšanas bojājumi, kas radušies transportēšanas laikā, vai virsmas bojājumi netiek atzīti.
- Caurulvadi un armatūra ir jāuzstāda, jāizskalo un jāpārbauda saskaņā ar spēkā esošajiem standartiem.
- Jāievēro attiecīgās valstīs spēkā esošās montāžas prasības.

## Tehniskie dati

### Jaucējkrāns tiek ražots kopā ar EcoSmart® (caurteces ierobežotāju)

Darba spiediens:	maks. 1 MPa
leteicamais darba spiediens:	0,1 - 0,5 MPa
Pārbaudes spiediens:	1,6 MPa
	(1 MPa = 10 bar = 147 PSI)

Izstrādājums ir paredzēts tikai dzeramajam ūdenim!

## Simbolu nozīme

 Neizmantoj silikonu, kas satur etiķskābi!

 **Izmērus** (skat. lpp. 22)

 **Caurplūdes diagramma** (skat. lpp. 22)

 **Rezerves daļas** (skat. lpp. 23)

## Speciāli aksesuāri

(komplektā netiek piegādāts)

 Apkopes atslēga #93913000 (skat. lpp. 23)

 **Tīrīšana** (skat. lpp. 24)

 **Lietošana** (skat. lpp. 20)

Hansgrohe iesaka no rīta vai pēc ilgākiem pārtraukumiem nelietot pirmo puslitru ūdens dzeršanai.

 **Pārbaudes zīme** (skat. lpp. 22)

## Sigurnosne napomene

- △ Prilikom montažē se radi sprečavanja prignječenja i posekotina moraju nositi rukavice.
- △ Proizvod sme da se koristi samo za kupanje, tuširanje i ličnu higijenu.

## Instrukcije za montažu

- Pre montaže se mora proveriti da li je proizvod oštećen pri transportu. Nakon ugradnje se ne priznaju nikakve reklamacije koje se odnose na površinska i transportna oštećenja.
- Vodovi i armatura moraju biti postavljeni, isprani i testirani prema važećim normama.
- Treba se pridržavati propisa koji u određenim zemljama važe za instalacije.

## Tehnički podaci

### Ove armature imaju serijski ugrađen EcoSmart® (ograničavač protoka vode)

Radni pritisak:	maks. 1 MPa
Preporučeni radni pritisak:	0,1 - 0,5 MPa
Probni pritisak:	1,6 MPa
	(1 MPa = 10 bar = 147 PSI)

Proizvod je koncipiran isključivo za pijaću vodu!

## Opis simbola

 Nemojte koristiti silikon koji sadrži sirćetnu kiselinu!

 **Mere** (vidi stranu 22)

 **Dijagram protoka** (vidi stranu 22)

 **Rezervni delovi** (vidi stranu 23)

**Poseban pribor** (Nije sadržano u isporuci)

 Servisni ključ #93913000 (vidi stranu 23)

 **Čišćenje** (vidi stranu 24)

 **Rukovanje** (vidi stranu 20)

Hansgrohe preporučuje da ujutru ili nakon dužeg nekorisćenja prvih pola litre vode ne koristite za piće.

 **Ispitni znak** (vidi stranu 22)



## Sikkerhetshenvisninger

- △ Bruk hansker under montasjen for å unngå klem- og kuttskader.
- △ Produktet skal kun brukes for bade-, hygiene- og kroppshygiene.

## Montagehenviisninger

- Før montasjen skal produktet sjekkes for transportskader. Etter monteringen aksepteres ikke noen transport- eller overflateskader.
- Ledningene og armaturen skal monteres, spyles og sjekkes iht. de gyldige normer.
- Gjeldende retningslinjer for rørleggerarbeid i de enkelte land skal følges.

## Tekniske data

### Armatur er standardmessig utstyrt med EcoSmart® (gjennomstrømningsbegrenser)

Driftstrykk	maks. 1 MPa
Anbefalt driftstrykk:	0,1 - 0,5 MPa
Prøvetrykk	1,6 MPa

(1 MPa = 10 bar = 147 PSI)

Produktet er utelukkende designet for drikkevann!

## Symbolbeskrivelse



Ikke bruk silikon som inneholder eddiksyre!



**Mål** (se side 22)



**Gjennomstrømningsdiagram**  
(se side 22)



**Servicedeler** (se side 23)



**Ekstratilbehør** (ikke med i leveransen)



Servicenøkkel #93913000 (se side 23)



**Rengjøring** (se side 24)



**Betjening** (se side 20)

Om morgen og etter lengre stagnasjonstider anbefaler Hansgrohe å ikke bruke den første halvliteren som drikkevann.



**Prøvemerket** (se side 22)



## Указания за безопасност

- △ При монтажа трябва да се носят ръкавици, за да се избегнат наранявания поради притискане или порязване.
- △ Позволено е използването на продукта само за къпане, хигиена и цели на почистване на тялото.

## Указания за монтаж

- Преди монтажа продуктът трябва да се провери за транспортни щети. След монтажа не се признават транспортни или повърхностни щети.
- Тръбопроводите и арматурата трябва да се монтира, промият и проверят в съответствие с валидните норми.
- Трябва да бъдат спазвани валидните в съответните страни предписания за инсталиране.

## Технически данни

### Арматурата е оборудвана серийно с EcoSmart® (ограничител на протичане)

Работно налягане:	макс. 1 МПа
Препоръчително работно налягане:	0,1 - 0,5 МПа
Контролно налягане:	1,6 МПа

(1 MPa = 10 bar = 147 PSI)

Продуктът е разработен само за питейна вода!

## Описание на символите



Не използвайте силикон, съдържащ оцетна киселина!



**Размери** (вижте стр. 22)



**Диаграма на потока**  
(вижте стр. 22)



**Сервизни части** (вижте стр. 23)

## Специални принадлежности

(не се съдържа в обема на доставка)



Сервизен ключ #93913000 (вижте стр. 23)



**Почистване** (вижте стр. 24)



**Обслужване** (вижте стр. 20)

Hansgrohe препоръчва, сутрин и след по-продължително спиране първият половин литър да не се използва като питейна вода.



**Контролен знак** (вижте стр. 22)





## ⚠ Udhëzime sigurie

- ⚠ Për të evituar lëndimet e pickimeve ose të prerjeve gjatë procesit të montimit duhet që të vishni doreza.
- ⚠ Produkti duhet të përdoret vetëm qëllimet e banjave, të higjienës dhe të larjes së trupit.

- ⚠ تنبيهات الأمان
- ⚠ يجب ارتداء قفازات لليد أثناء التركيب لتجنب حدوث أخطار الإنحشار أو الجروح.
- ⚠ لا يجب استخدام المنتج إلا في أغراض الاستحمام والأغراض الصحية وأغراض تنظيف الجسم.

## Udhëzime për montimin

- Përpara montimit duhet që produkti të kontrollohet për dëmtime nga transporti. Pas instalimit nuk do të njihet asnjë dëmtim nga transporti ose dëmtim i sipërfaqes.
- Tubacionet dhe rubinetet duhet që të montohen, të shpëlahen dhe të kontrollohen sipas standardeve në fuqi
- Duhet të respektohen linjat udhëzuese të instalimit, të vlefshme për vendet respektive.

- تعليمات التركيب
- قبل القيام بعملية التركيب، يجب فحص المنتج للتأكد من خلوّه من أية تلفيات ناتجة عن النقل. بعد القيام بعملية التركيب، لن يتم الاعتراف بوجود أية تلفيات سطحية أو تلفيات ناتجة عن عملية النقل.
- يجب تركيب وغسيل واختبار التوصيلات وخلطات المياه طبقاً للمعايير السارية.
- يجب مراعاة القواعد الخاصة بالتركيب وأعمال السباكة وفقاً للوائح الخاصة بكل بلد.

## Të dhëna teknike

### Rubineti është i pajisur si standard me EcoSmart® (Kufizues qarkullimi)

Presioni gjatë punës	maks. 1 MPa
Presioni i rekomanduar:	0,1 - 0,5 MPa
Presioni për provë:	1,6 MPa
	(1 MPa = 10 bar = 147 PSI)

Produkti është projektuar ekskluzivisht për ujë të pijshëm!

المواصفات الفنية  
يتم بشكل قياسي إنتاج الخلاط هذا مع EcoSmart® (محدد تدفق المياه)

الحد الأقصى 1 ميغاباسكال	ضغط التشغيل:
0,1 - 0,5 ميغاباسكال	ضغط التشغيل الموصى به:
1,6 ميغاباسكال	ضغط الاختبار:
(MPa = 10 bar = 147 PSI 1)	المنتج مخصص فقط لماء الشرب!

## Përshkrimi i simbolit

 Mos përdorni silikon që në përbërje ka acid acetik.

 هام! لا تستخدم السليكون الذي يحتوي على أحماض!

 **Përmasat** (shih faqen 22)

 أبعاد (راجع صفحة 22)

 **Diagrami i qarkullimit**  
(shih faqen 22)

 رسم للصرف (راجع صفحة 22)

 **Pjesët e servisit** (shih faqen 23)

 قطع الغيار (راجع صفحة 23)

## Pajisje të posaçme

(nuk përfshihet në vëllimin e furnizimit)

 Çelësi i servisit #93913000 (shih faqen 23)

 مفتاح الخدمة #93913000 (راجع صفحة 23)

 **Pastrimi** (shih faqen 24)

 التنظيف (راجع صفحة 24)

 **Përdorimi** (shih faqen 20)

 التشغيل (راجع صفحة 20)

Hansgrohe rekomandon që në mëngjes ose pas periudhave të gjata që gjysmë litri i parë mos të pihet

تنصح شركة هانزجر وهي Hansgrohe بعدم استخدام أول نصف لتر من الماء لغرض الشرب وذلك في الصباح أو بعد توقف استخدام الماء لفترات طويلة نسبياً.

 **Shenja e kontrollit** (shih faqen 22)

 شهادة اختبار (راجع صفحة 22)

## Montimi

(shih faqen 18) 

## التركيب

(راجع صفحة 18) 



## Biztonsági utasítások

- ⚠ A szerelésnél a zúzódasok és vágási sérülések elkerülése érdekében kesztyűt kell viselni.
- ⚠ A terméket csak fürdéshez, mosakodáshoz, és egészségügyi tisztálkodáshoz szabad használni.

## Szerelési utasítások

- A szerelés előtt ellenőrizni kell, hogy a terméknek nincs-e szállítási sérülése. Beépítés után a szállítási- vagy felületi sérüléseket nem ismerik el.
- A vezetékeket és a csaptelepet az érvényes szabványoknak megfelelően kell felszerelni, öblíteni és ellenőrizni
- Az egyes országokban érvényes installációs irányelveket be kell tartani.

## Műszaki adatok

### A csaptelep szériakivitelben el van látva

### EcoSmart® (átfolyáskorlátozó) berendezéssel

Üzemi nyomás: max. 1 MPa

Ajánlott üzemi nyomás: 0,1 - 0,5 MPa

Nyomáspróba: 1,6 MPa

(1 MPa = 10 bar = 147 PSI)

A terméket kizárólag ivóvízhez tervezték!

## Szimbólumok leírása



Ne használjon ecetsavtartalmú szilikon!



**Méretet** (lásd a oldalon 22)



**Átfolyási diagramm**

(lásd a oldalon 22)



**Tartozékok** (lásd a oldalon 23)

## Egyéb tartozék

(a szállítási egység nem tartalmazza)



Szervíz kulcs #93913000 (lásd a oldalon 23)



**Tisztítás** (lásd a oldalon 24)



**Használat** (lásd a oldalon 20)

- A csaptelepeken átfolyt víz hőmérséklete fogyasztásra szánt víz esetében a 65°C-ot nem haladhatja meg. A csaptelep nem eredményezheti az emberi fogyasztásra (pl. ivás és főzés céljából) szánt víz minőségromlását.

- Beüzemelés és üzemszünetek után szigorúan be kell tartani a használati útmutatóban leírtakat. Beüzemeléskor a csaptelepet át kell öblíteni, legalább 2 percig történő hideg- és melegvízes folyamatot javasolunk. Minimum 1 napos üzemszünet után fogyasztás előtt a csaptelepben stagnáló hideg- illetve melegvíz fogyasztása nem javasolt, a csaptelepben stagnáló vizet ki kell engedni, legalább 2 perces folyamatot javasolt. A kifolyatás során nyert vizet ivóvízként, illetve ételkészítési céllal felhasználni nem szabad.
- Tekintettel arra, hogy a forró víz fémoldó képessége a hideg víznél nagyobb, emiatt főzés ivás céljából az OKI a hideg víz használatát javasolja.
- A csaptelepek perlátorát javasolt havonta vízkőtelepíteni, illetve fertőtleníteni. A csaptelepek tisztítása, fertőtlenítése során kizárólag olyan vegyszer alkalmazható, amely megfelel a 201/2001. (X.25) Kormányrendelet, illetve a 38/2003. (VII.7) ÉSzcsm-FVM-KvVM együttes rendeletben leírtaknak.
- A perlátor működési elvéből adódóan jelentős aeroszolt képez, így Legionella expozíció szempontjából fokozott kockázatot jelent. Ezért alkalmazása nem javasolt az egészségügyi intézmények fekvőbeteg ellátó szobáiban, illetve minden olyan helyen, ahol a hideg és / vagy használati melegvíz Legionella csíraszáma eléri a 49/2015 (XI.6.) EMMI rendelet alapján meghatározott beavatkozási szintet.



**Vizsgajel** (lásd a oldalon 22)





## Güvenlik uyarıları

- △ Montaj esnasında ezilme ve kesilme gibi yaralanmaları önlemek için eldiven kullanılmalıdır.
- △ Ürün yalnızca banyo, hijyen ve beden temizliği amaçları doğrultusunda kullanılabilir.

## Montaj açıklamaları

- Montaj işleminden önce ürün nakliye hasarları yönünden kontrol edilmelidir. Montaj işleminden sonra nakliye veya yüzey hasarları için sorumluluk üstlenilmemektedir.
- Boruların ve armatürün montajı, yıkanması ve kontrolü geçerli normlara göre yapılmalıdır.
- Ülkelerde geçerli kurulum yönetmeliklerine riayet edilmelidir.

## Teknik bilgiler

### Batarya EcoSmart® (akış sınırlayıcısı) ile birlikte seri olarak

İşletme basıncı:	azami 1 MPa
Tavsiye edilen işletme basıncı:	0,1 - 0,5 MPa
Kontrol basıncı:	1,6 MPa

(1 MPa = 10 bar = 147 PSI)

Ürün sadece şebeke suyu için tasarlanmıştır!

## Simge açıklaması



Asetik asit içeren silikon kullanmayın!



**Ölçüleri** (bakınız sayfa 22)



**Akış diyagramı** (bakınız sayfa 22)



**Yedek Parçalar** (bakınız sayfa 23)

## Özel aksesuarlar

(Teslimat kapsamına dahil değildir)



Servis anahtarı #93913000 (bakınız sayfa 23)



**Temizleme** (bakınız sayfa 24)



**Kullanımı** (bakınız sayfa 20)

Hansgrohe sabahları uzun durgunluk süresi sonrasında ilk yarım litre suyun içme suyu olarak kullanılmamasını önerir.



**Kontrol işareti** (bakınız sayfa 22)

## Garanti Belgesi

### Üretici veya İthalatçı Firmanın

Unvanı: Hansgrohe Armatür Ltd. Şti  
Adresi: Fulya Mahallesi Bahçeler Sokak Efe han 20/C  
Mecidiyeköy Şişli İstanbul  
Telefonu: (0-212) 273 07 30  
Faks: (0-212) 273 07 40  
web adresi: www.hansgrohe.com.tr

## Malın

Markası: Hansgrohe  
Cinsi: Sıhhi tesisat malzemesi  
Garanti Süresi: 2 YIL  
Azami Tamir Süresi: 20 İş günü

## Genel Müdür

Albert Emlek

Satıcı Firmanın:

Unvanı:

Adresi:

Telefonu:

Faks:

e-posta:

Fatura Tarih ve Sayısı:

Marka ve Modeli:

Teslim Tarihi ve Yeri:

Yetkilinin İmzası:

Firmanın Kaşesi:

Bu bölümü, ürünü aldığınız Yetkili Satıcı imzalayacak ve kaşeyecektir.

## Montajı

(bakınız sayfa 18)

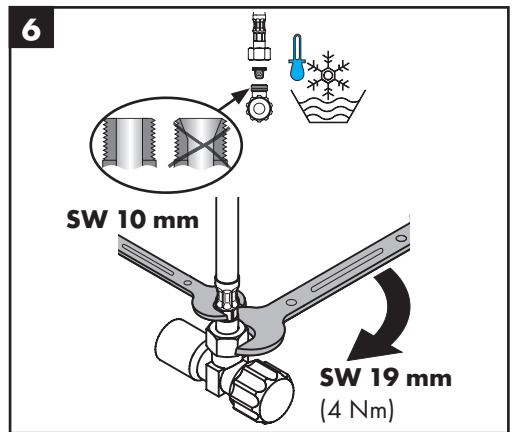
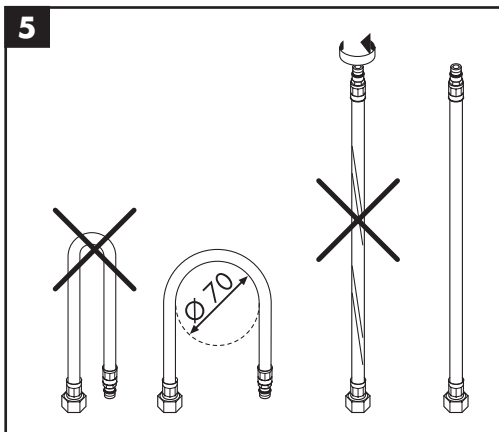
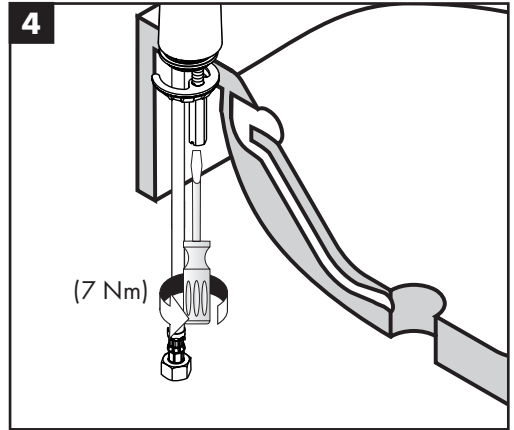
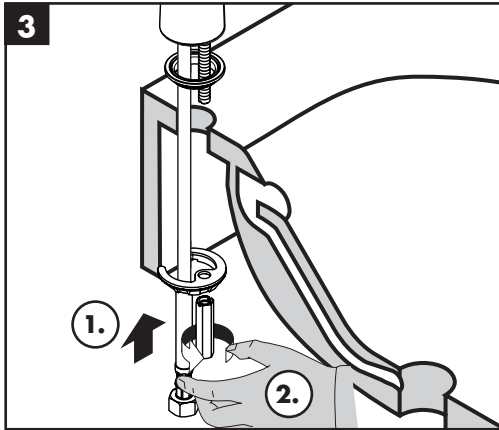
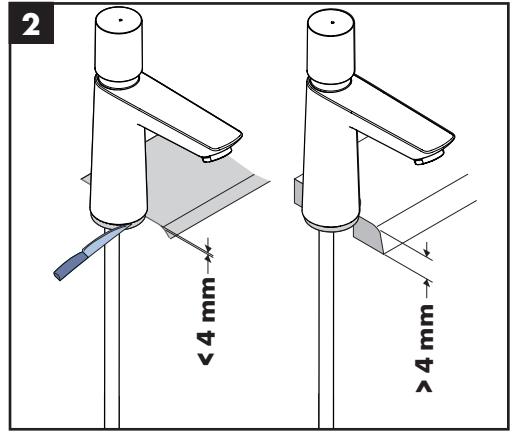
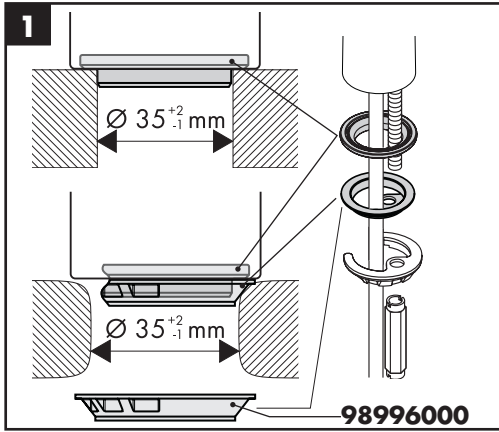

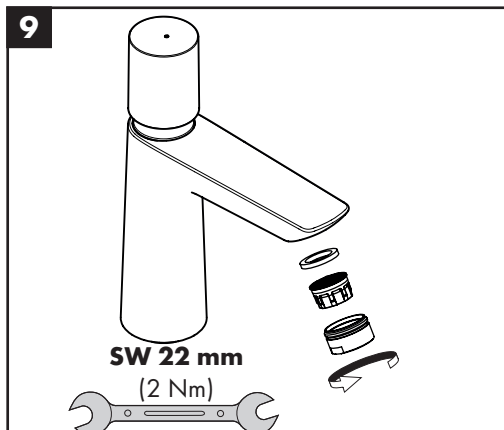
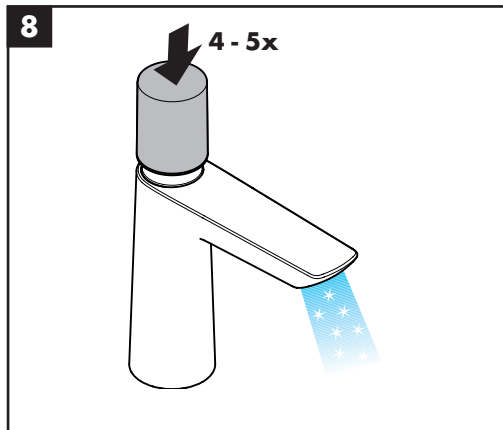
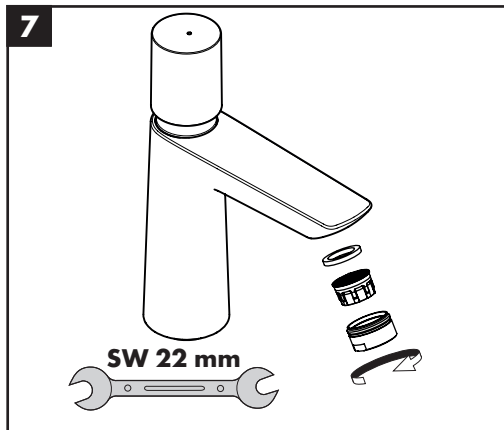

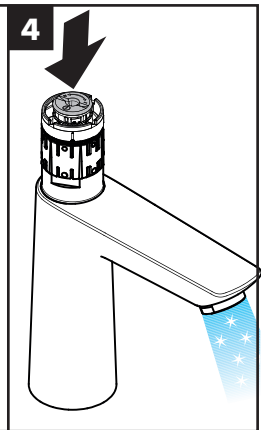
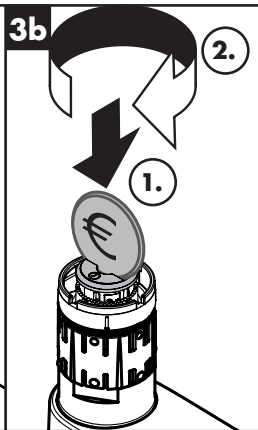
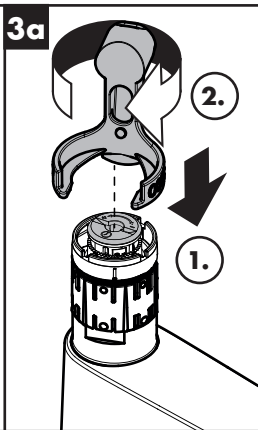
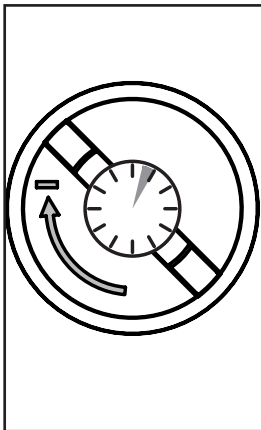
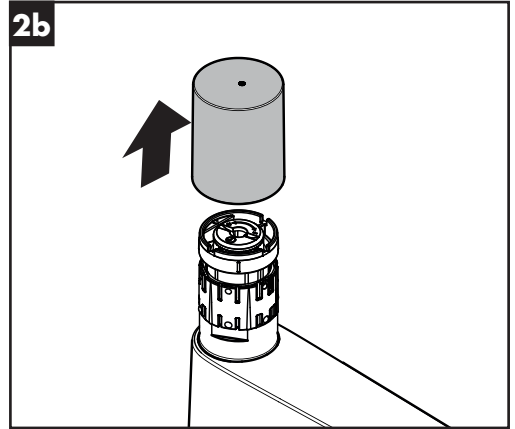
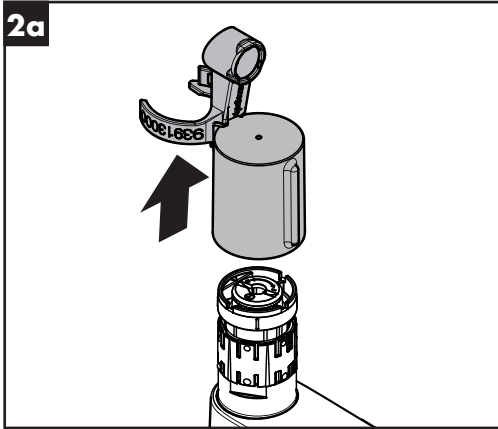
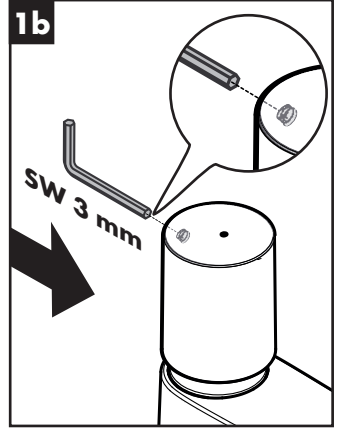
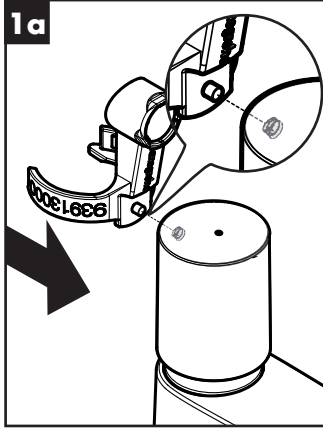
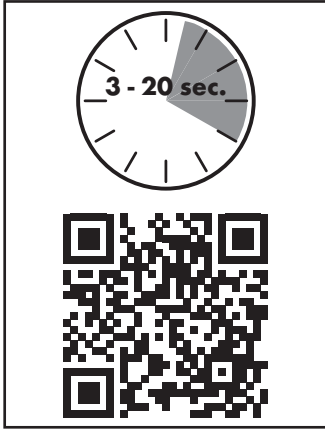

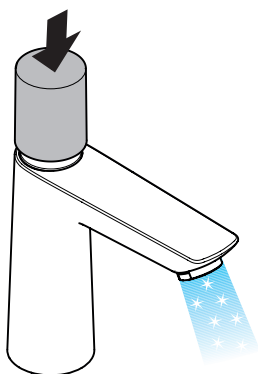
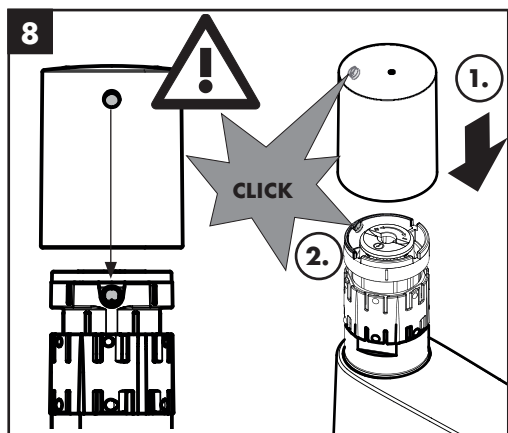
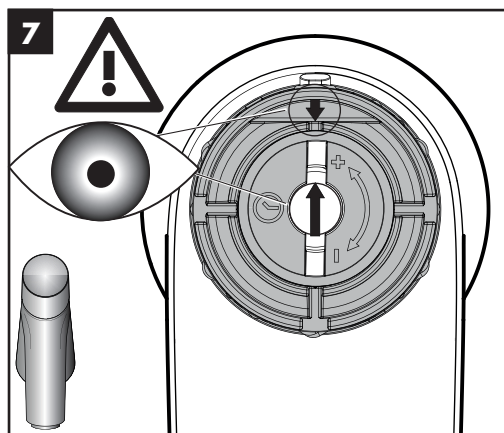
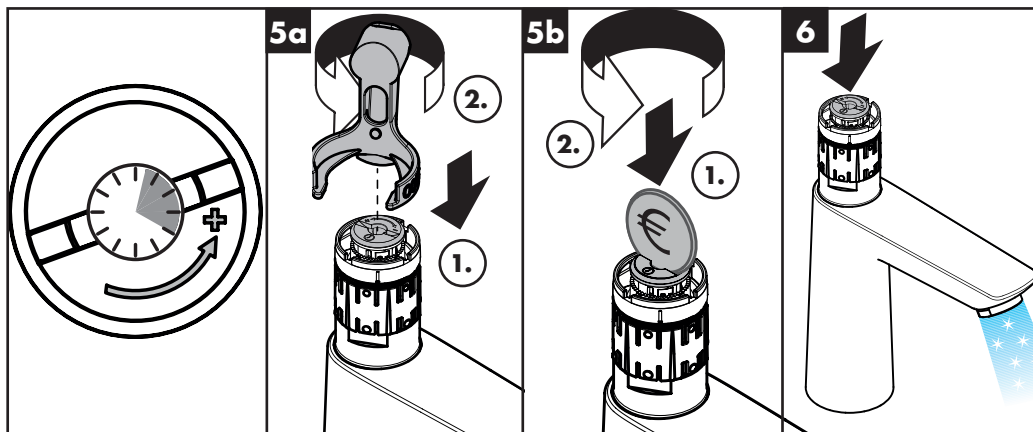

öffnen / ouvert / open /  
 aperto / abierto / open /  
 åbne / abrir / otworzyć /  
 otevřít / otvorit' / 开 /  
 открыть / nyitás /  
 avaaminen / öppna /  
 atidaryti / Otvaranje /  
 açmak / deschide /  
 ανοικτό / odpreti /  
 avage / atvērt / otvoriti /  
 åbne / отварање / hare /  
 فتح / 開く

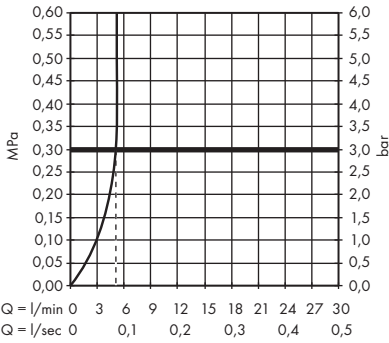
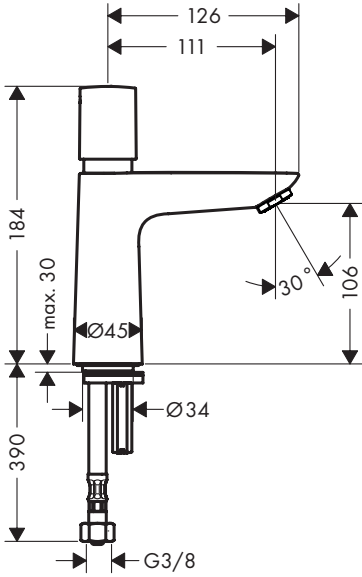

P-IX

DVGW SINTEF NF



71400000 PIX 17545/IO

Hansgrohe SE

DIN 4109-1

PIX 17545/IO

MPA NRW.



**Talis E**  
71719000

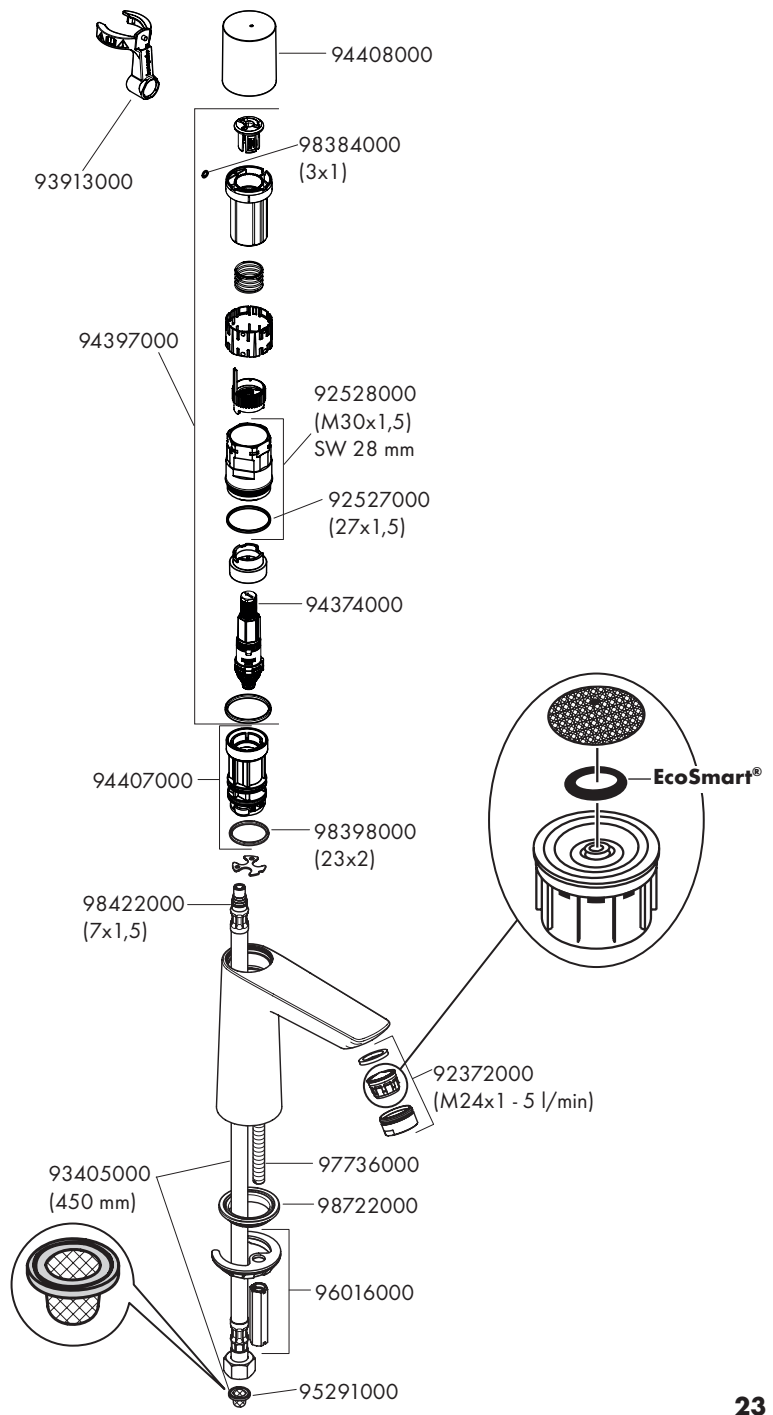



- DE** Reinigungsempfehlung / Garantie / Kontakt
- FR** Recommandation pour le nettoyage / Garanties / Contact
- EN** Cleaning recommendation / Warranty / Contact
- IT** Raccomandazione di pulizia / Garanzia / Contatto
- ES** Recomendaciones para la limpieza / Garantía / Contacto
- NL** Aanbevelingen inzake reiniging / Garantie / Contact
- DK** Rengøringsvejledning / Garanti / Kontakt
- PT** Recomendações de limpeza / Garantia / Contacto
- PL** Zalecenie dotyczące pielęgnacji / Gwarancja / Kontakt
- CS** Doporučení k čištění / Záruka / Kontakt
- SK** Odporúčania pre čistenie / Záruka / Kontakt
- ZH** 清洁指南 / 担保 / 接触
- RU** Рекомендации по очистке / Гарантия / Контакты
- FI** Puhdistussuositus / Takuu / Kosketus
- SV** Rengöringsrekommendationer / Garanti / Contacto
- LT** Valymo rekomendacijos / Garantija / Kontaktai
- HR** Preporuke za čišćenje / Garancija / Kontakt
- TR** Temizleme önerisi / Garanti / Temas
- RO** Recomandări pentru curățare / Garanție / Contact
- EL** Σύσταση καθαρισμού / Εγγύηση / επαφή
- SL** Priporočilo za čiščenje / Garancija / Kontakt
- ET** Puhastussuovitused / Garantii / Kontakt
- LV** Tīrīšanas ieteikumi / Garantija / Kontakti
- SR** Preporuke za čišćenje / Garancija / Kontakt
- NO** Anbefaling for rengjøring / Garanti / Kontakt
- BG** Препоръка за почистване / Гаранция / Контакт
- SQ** Këshilla rreth pastrimit / Garancia / Kontakt
- KO** 세정시 권장사항 / 품질보증 / 접촉
- AR** توصيات التنظيف / الضمان / اتصال
- HU** Tisztítási tanácsok / Garancia / érintkezés
- JP** お手入れの方法 / 保証について / ご連絡先



[www.hansgrohe.com/  
cleaning-recommendation](http://www.hansgrohe.com/cleaning-recommendation)

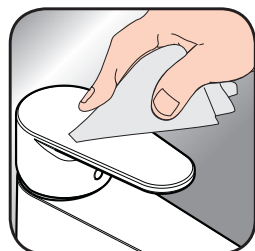

[www.hansgrohe.com/  
cleaning-recommendation](http://www.hansgrohe.com/cleaning-recommendation)



[www.hansgrohe.com/  
cleaning-recommendation](http://www.hansgrohe.com/cleaning-recommendation)



[www.hansgrohe.com/  
cleaning-recommendation](http://www.hansgrohe.com/cleaning-recommendation)