

# F5

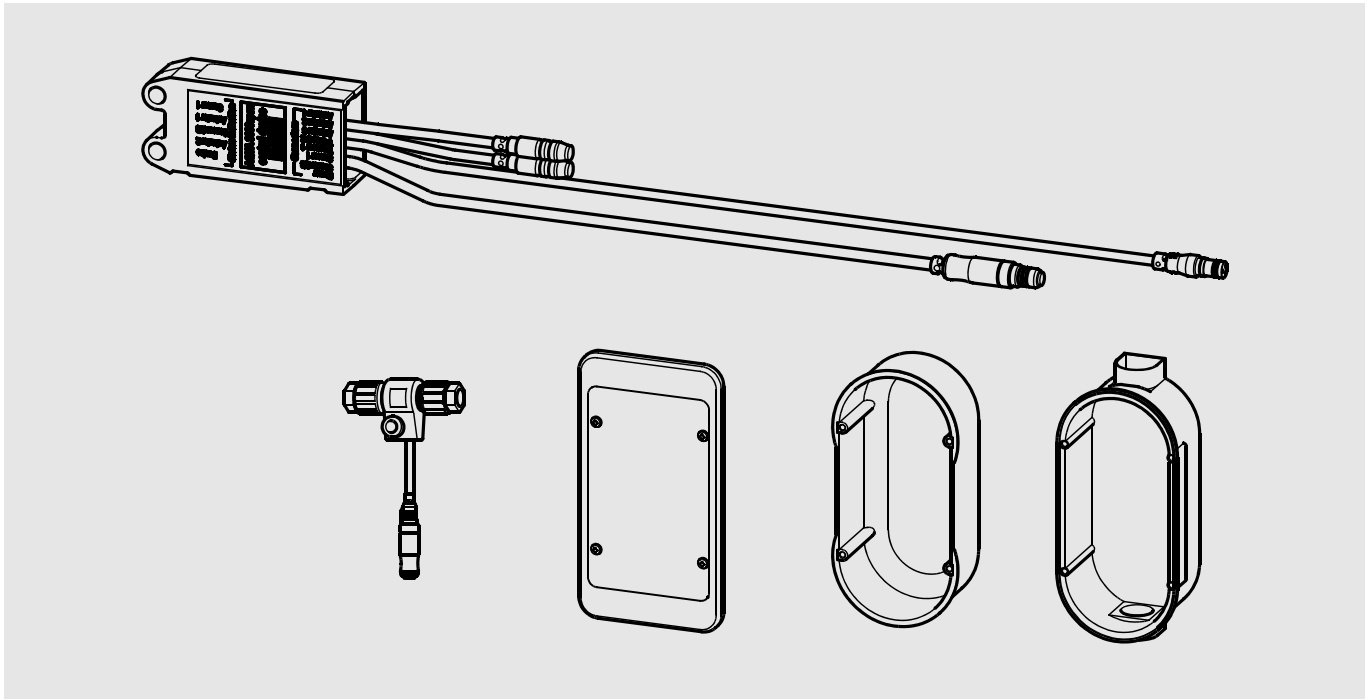

**ACEX1004**  
2030059118

**ACEM1002**  
3600000505

<b>DE</b>	Montage- und Betriebsanleitung	Elektronikmodul EM5
<b>EN</b>	Installation and operating instructions	Electronic module EM5
<b>FR</b>	Notice de montage et de mise en service	Module électronique EM5
<b>ES</b>	Instrucciones de montaje y servicio	Modulo electrónico EM5
<b>IT</b>	Istruzioni per il montaggio e l'uso	Modulo elettronico EM5
<b>NL</b>	Montage- en bedrijfsinstructies	Elektronische module EM5
<b>PL</b>	Instrukcja montażu i obsługi	
<b>SV</b>	Monterings- och driftinstruktion	
<b>CS</b>	Návod pro montáž a provoz	
<b>FI</b>	Asennus- ja käyttöohje	Elektroniikkamoduuli EM5
<b>RU</b>	Инструкция по монтажу и вводу в эксплуатацию	

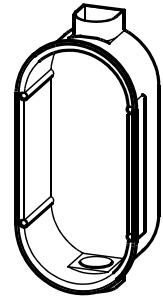
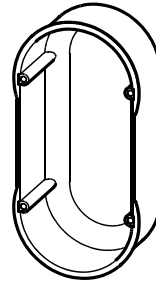
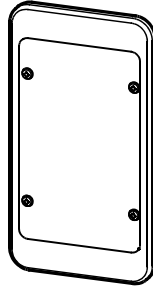
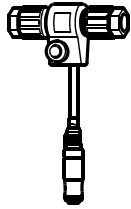
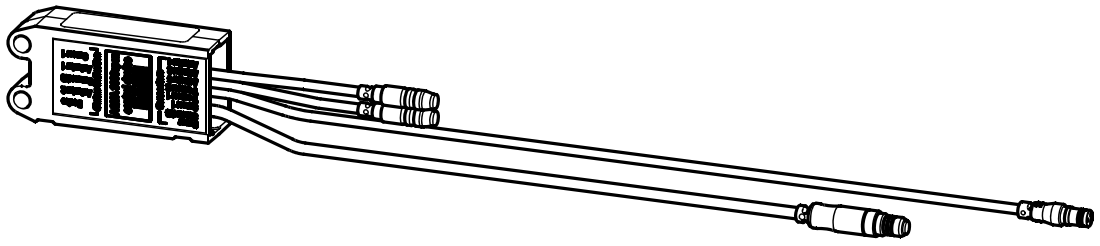

	ID
<b>ACEX1004</b>	<b>02010</b>
<b>ACEM1002</b>	<b>02160</b>

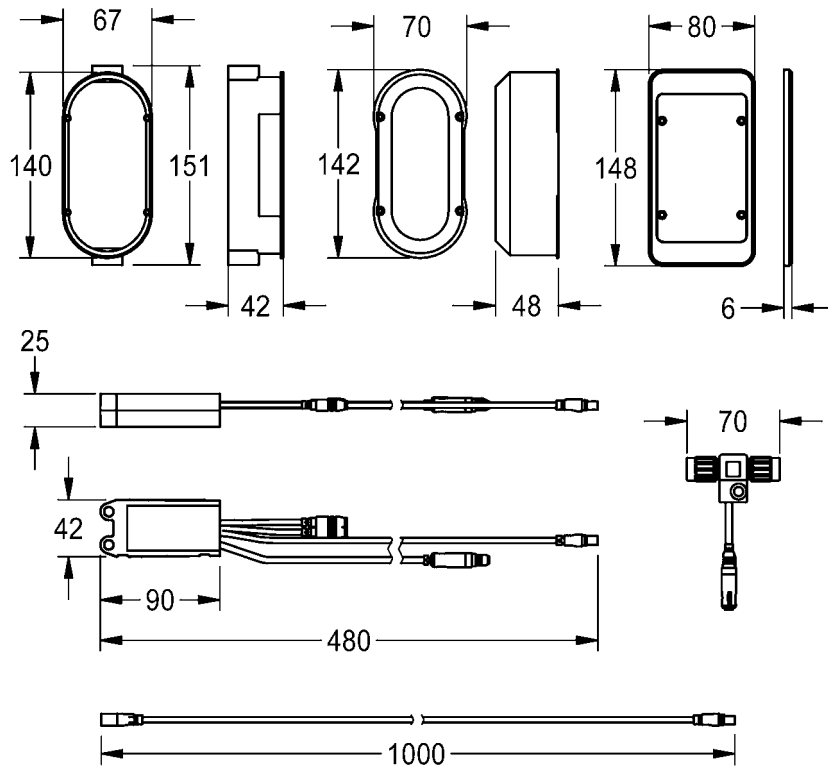
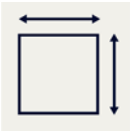



**ACEX1004**

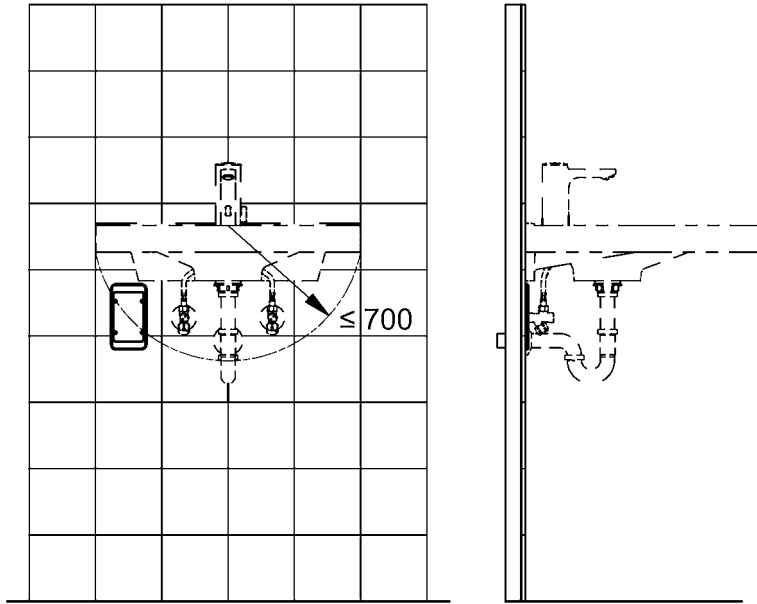

**ACEM1002**

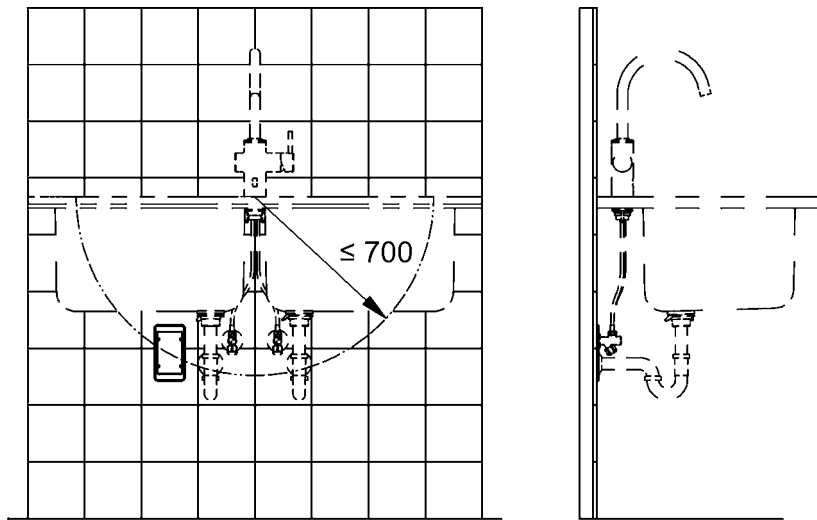

**EN**

## Installation and operating instructions

### Important notes

- ▶ Operate the product only with safety extra low voltage (SELV). The components must not be earthed.
- ▶ Place the power supply (not part of the delivery, see accessories) outside the wet area in a separate room.
- ▶ Protect the power supply with a residual current circuit breaker (RCD).
- ▶ All work must be carried out in a de-energised state.

### Technical data

- ▶ Supply voltage 24 V DC
- ▶ Power consumption 1W
- ▶ Type of protection IP 68

**PL**

## Instrukcja montażu i obsługi

### Ważne wskazówki

- ▶ Produkt użytkować wyłącznie z bardzo niskim napięciem bezpiecznym (SELV). Elementy konstrukcyjne nie mogą być uziemione.
- ▶ Zasilacz elektryczny (nie znajduje się w zakresie dostawy, zobacz akcesoria) umieścić poza obszarem wilgotności w innym pomieszczeniu.
- ▶ Należy wykonać przyłącze elektryczne z wyłącznikiem różnicowoprądowym (RCD).
- ▶ Wszystkie prace przeprowadzać po odłączeniu zasilania elektrycznego.

### Dane techniczne

- ▶ Napięcie przyłączeniowe 24 V DC
- ▶ Pobór mocy 1 W
- ▶ Rodzaj ochrony IP 68

**DE**

## Montage- und Betriebsanleitung

### Wichtige Hinweise

- ▶ Das Produkt nur mit Schutzkleinspannung (SELV) betreiben. Die Bauteile dürfen nicht geerdet werden.
- ▶ Die Spannungsversorgung (nicht Lieferumfang, Zubehör) außerhalb des Nassbereichs in einem extra Raum platzieren.
- ▶ Den Elektroanschluss mit einem Fehlerstromschutzschalter (RCD) absichern.
- ▶ Alle Arbeiten im spannungsfreien Zustand durchführen.

### Technische Daten

- ▶ Anschlussspannung 24 V DC
- ▶ Leistungsaufnahme 1 W
- ▶ Schutzart IP 68

**SV**

## Monterings- och driftinstruktion

### Viktiga informationer

- ▶ Använd produkten endast med extra låg skyddsspänning (SELV). Komponenterna får inte jordas.
- ▶ Placera strömförsörjningen (ingår inte i leveransen, se tillbehör) utanför det våta området i ett separat utrymme.
- ▶ Säkra elanslutningen med en jordfelsbrytare (RCD).
- ▶ Genomför alla arbeten i spänningslöst tillstånd.

### Tekniska data

- ▶ Anslutningsspänning 24 V DC
- ▶ Effektbehov 1 W
- ▶ Skyddsklass IP 68

**FR**

## Notice de montage et de mise en service

### Remarques importantes

- ▶ Ne faire fonctionner le produit qu'à très basse tension de sécurité (SELV). Les composants ne doivent pas être mis à la terre.
- ▶ Placer l'alimentation en tension (non fournie, voir Accessoires) hors de la zone humide dans une autre pièce.
- ▶ Protéger le raccordement électrique avec un interrupteur de protection contre les courants de court-circuit (RCD).
- ▶ Effectuez tous les travaux quand le dispositif est hors tension.

### Données techniques

- ▶ Tension de raccordement 24 V DC
- ▶ Puissance absorbée 1 W
- ▶ Type de protection IP 68

**ES**

## Instrucciones de montaje y servicio

### Indicaciones importantes

- ▶ Utilizar el producto solamente con baja tensión de protección (SELV). No se permite conectar los componentes a tierra.
- ▶ Colocar el suministro eléctrico (no incluido en el volumen de suministro, véase Accesorios) fuera de la zona húmeda, en un espacio extra.
- ▶ Asegurar la conexión eléctrica mediante un interruptor diferencial de corriente residual (RCD).
- ▶ Todos los trabajos deben realizarse con la tensión de alimentación desconectada.

### Datos técnicos

- ▶ Tensión de conexión 24 V DC
- ▶ Consumo de potencia 1 W
- ▶ Modo de protección IP 68

**CS**

## Návod pro montáž a provoz

### Důležité pokyny

- ▶ Výrobek používejte pouze s bezpečným nízkým napětím (SELV). Komponenty se nesmějí uzemňovat.
- ▶ Zdroj napájení (není součástí dodávky, viz příslušenství) nainstalujte mimo mokrou oblast v oddělené místnosti.
- ▶ Elektrické připojení jistěte proudovým chráničem (RCD).
- ▶ Veškeré práce vykonávejte ve stavu bez napětí.

### Technické údaje

- ▶ Přípojné napětí 24 V DC
- ▶ Příkon 1 W
- ▶ Krytí IP 68

**FI**

## Asennus- ja käyttöohje

### Tärkeitä ohjeita

- ▶ Käytä tuotetta vain suojapienjännitteellä (SELV). Rakenneosia ei saa maadoittaa.
- ▶ Sijoita virransyöttö (ei sisälly toimituskokonaisuuteen, katso lisävarusteet) erilliseen tilaan märän alueen ulkopuolelle.
- ▶ Suojaa sähköliitintä vikavirtakytkimellä (RCD).
- ▶ Kaikki työt on tehtävä jännitteettömälle järjestelmälle.

### Tekniset tiedot

- ▶ Verkkojännite 24 V DC
- ▶ Tehonkulutus 1 W
- ▶ Suojaustapa IP 68

**IT**

## Istruzioni per il montaggio e l'uso

### Avvertenze importanti

- ▶ Far funzionare il prodotto solo con una bassissima tensione di sicurezza (SELV). Non collegare a massa i componenti.
- ▶ Collocare il sistema di alimentazione della tensione (non compreso nella fornitura, vedere Accessori) al di fuori della zona umida in un locale separato.
- ▶ Proteggere il collegamento elettrico con un interruttore differenziale (RCD).
- ▶ Eseguire tutti i lavori fuori tensione.

### Specifiche tecniche

- ▶ Tensione di allacciamento 24 V DC
- ▶ Potenza assorbita 1 W
- ▶ Tipo di protezione IP 68

**NL**

## Montage- en bedrijfsinstructies

### Belangrijke aanwijzingen

- ▶ Gebruik het product alleen met zeer lage veiligheidsspanning (SELV). De onderdelen mogen niet worden geaard.
- ▶ Plaats de stroomvoorziening (niet meegeleverd, zie Toebehoren) buiten het natte bereik in een aparte ruimte.
- ▶ Elektrische aansluiting met een aardlekschakelaar (RCD) beveiligen.
- ▶ Alle werkzaamheden in spanningsloze toestand uitvoeren.

### Technische gegevens

- ▶ Aansluitspanning 24 V DC
- ▶ Opgenomen vermogen 1 W
- ▶ Veiligheidsgraad IP 68

**RU**

## Инструкция по монтажу и вводу в эксплуатацию

### Важные указания

- ▶ Для работы изделия используется безопасное сверхнизкое напряжение (БСНН). Не разрешается заземлять компоненты.
- ▶ Разместить источник питания (не входит в комплект поставки, см. «Принадлежности») за пределами зоны повышенной влажности в другом помещении.
- ▶ Для защиты электрического подключения требуется установить устройство защитного отключения (УЗО).
- ▶ Выполняйте все работы при отключенном напряжении.

### Технические характеристики

- ▶ Напряжение питающей сети 24 В постоянного тока
- ▶ Потребляемая мощность 1 Вт
- ▶ Вид защиты IP 68

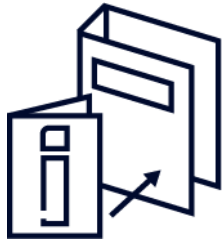

# 1. Montage

EN Installation  
FR Montage  
ES Montaje  
IT Montaggio

NL Montage  
PL Montaż  
SV Montering

CS Montáž  
FI Asennus  
RU Монтаж

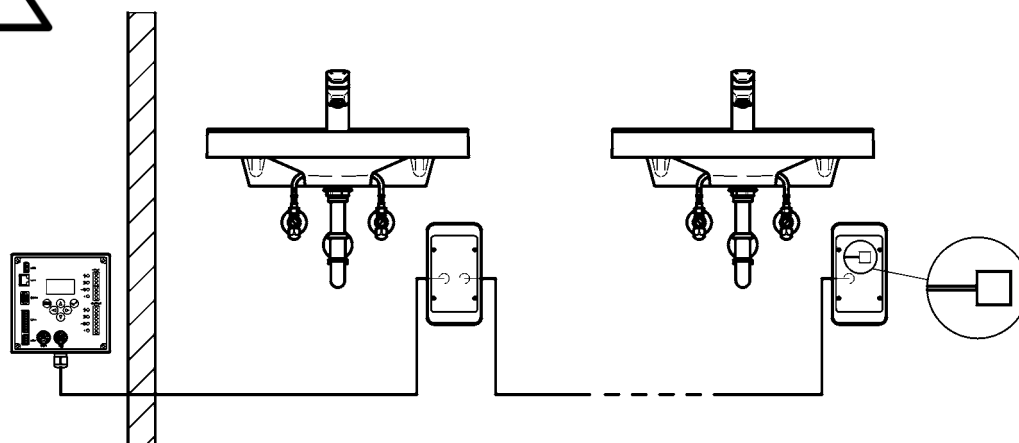
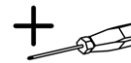
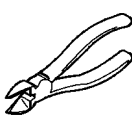
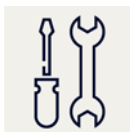

I

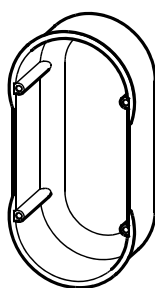
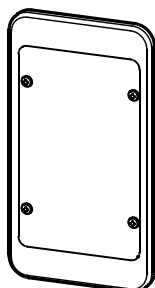

II

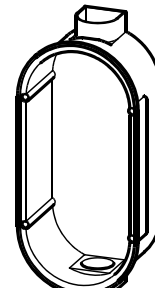
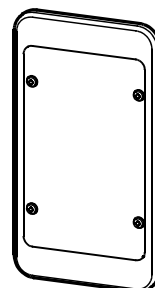



**1**

**I**

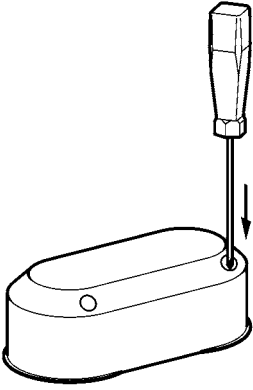

**II**

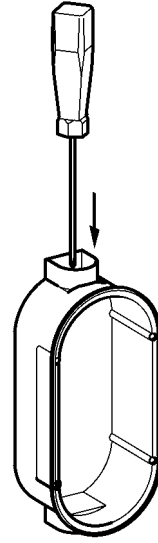

**2**

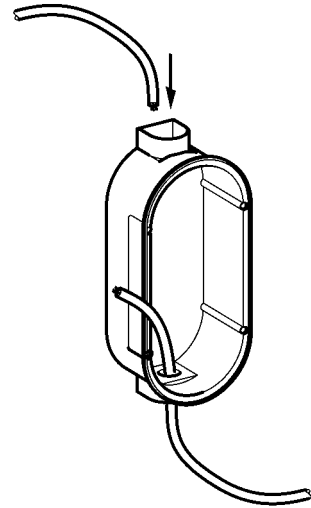
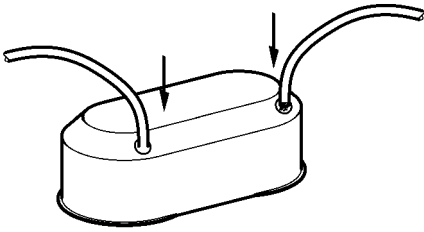

**3**

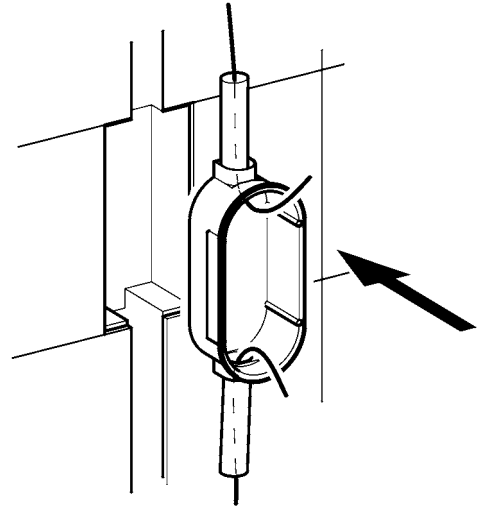
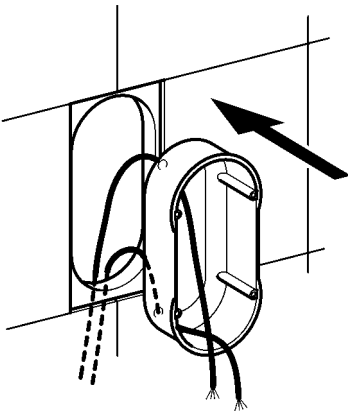

I

II

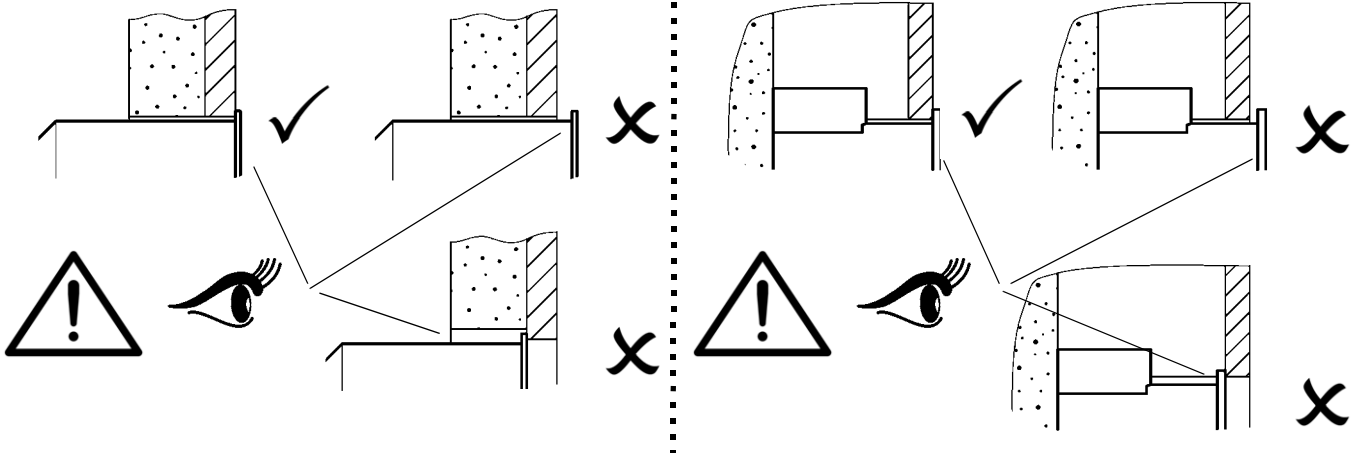

4

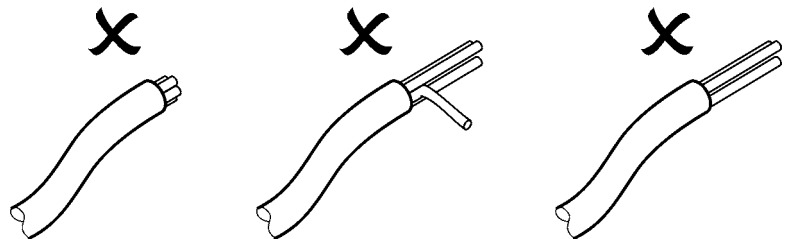
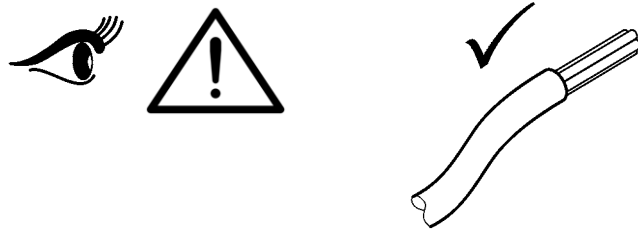
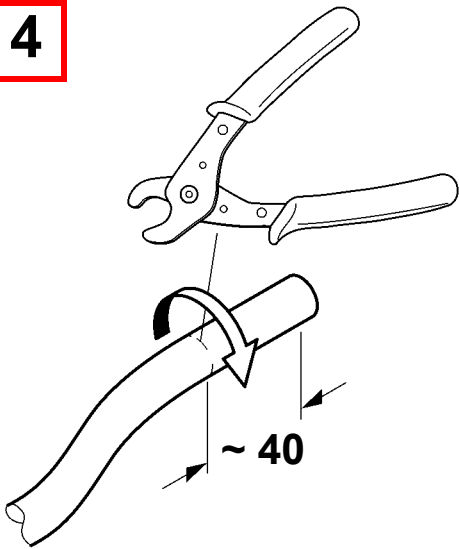

**5**

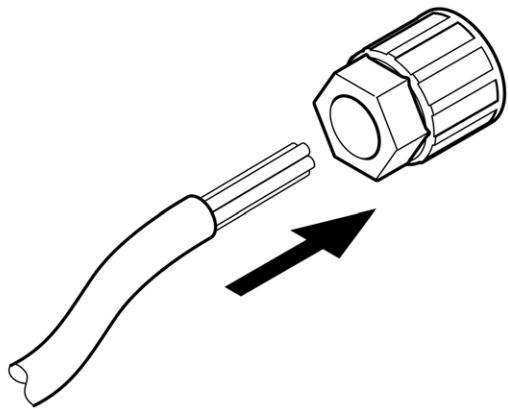

**6**

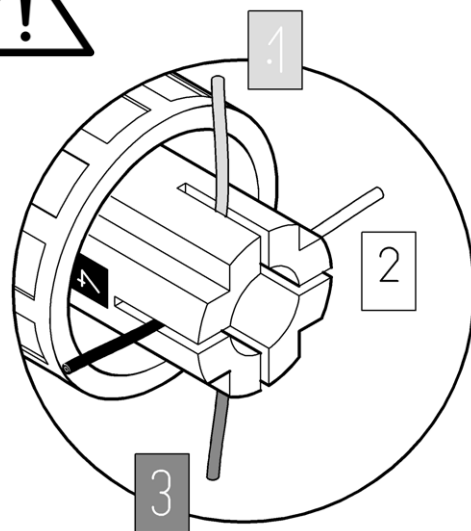
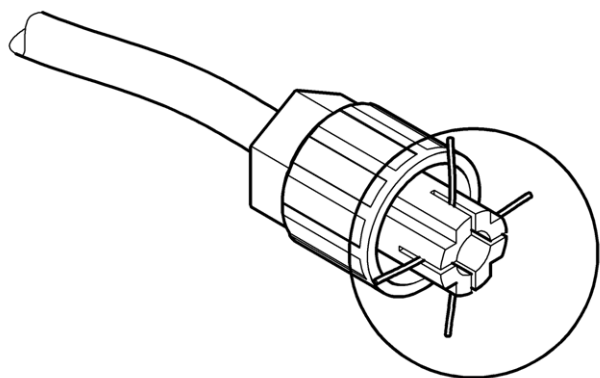

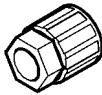
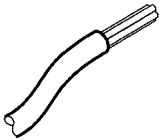
		
<b>1</b>	<b>brown</b>	<b>red</b>
<b>2</b>	<b>white</b>	<b>white</b>
<b>3</b>	<b>blue</b>	<b>blue</b>
<b>4</b>	<b>black</b>	<b>black</b>

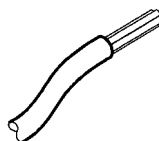

**3.**

**7**

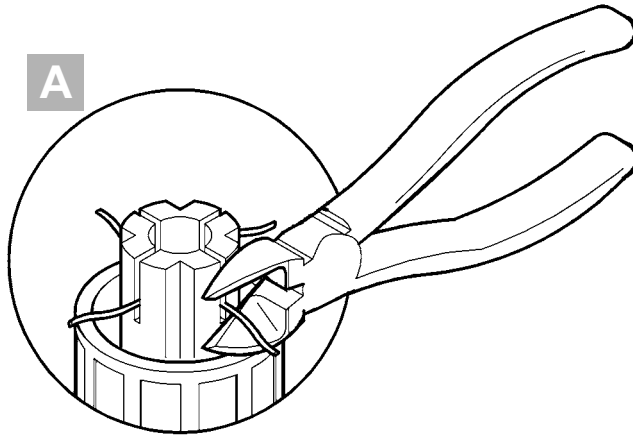
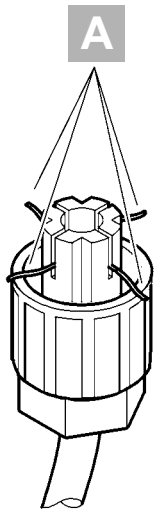

**8**

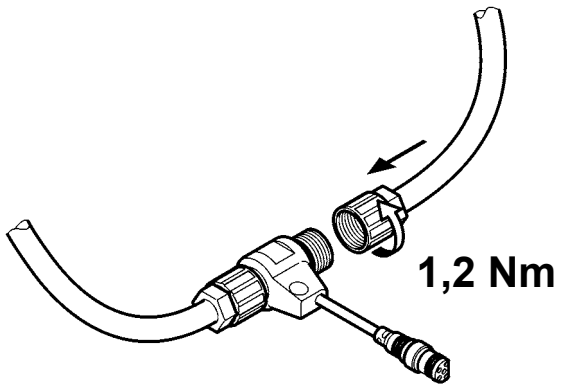

**9**

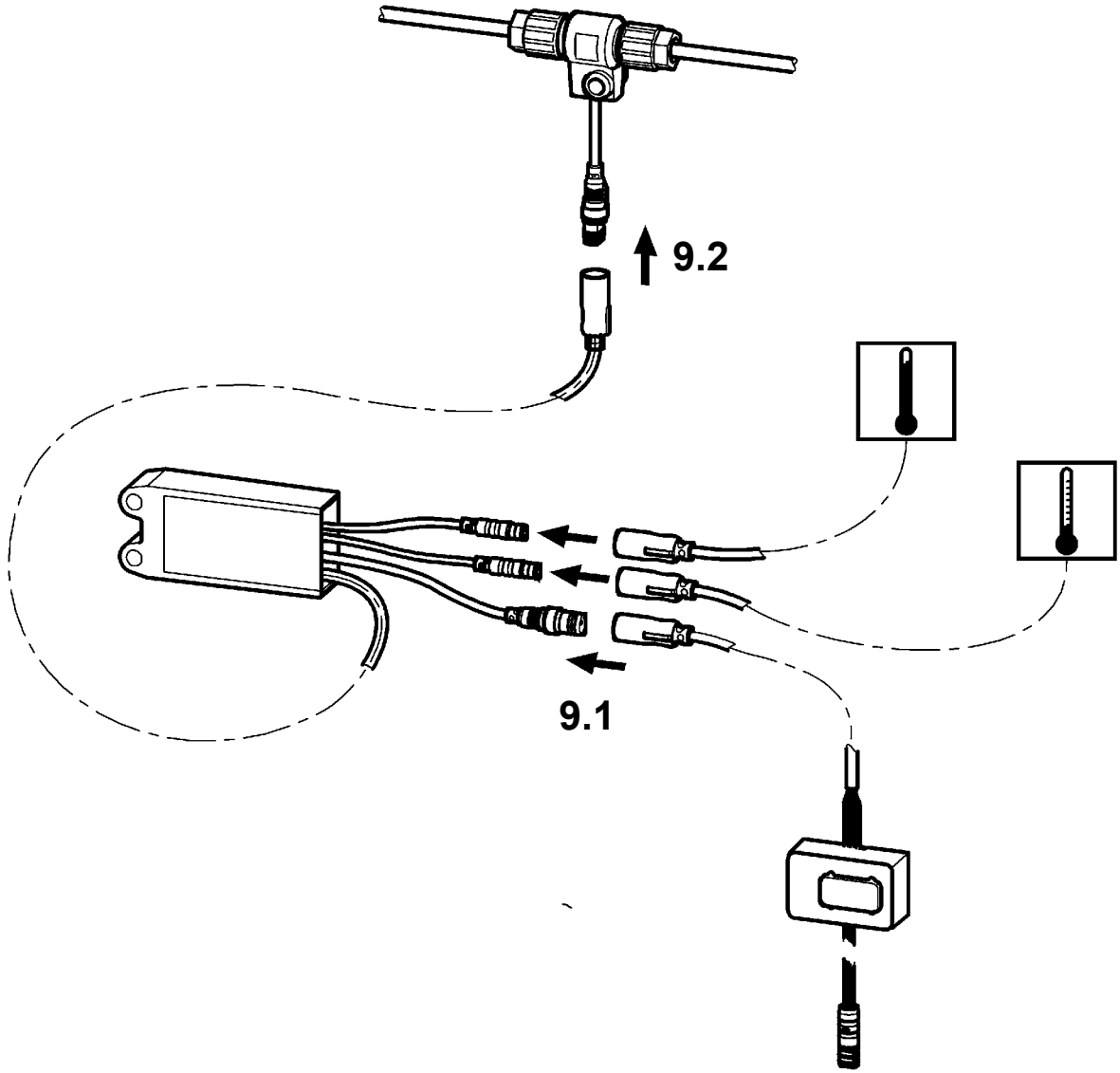

**10**

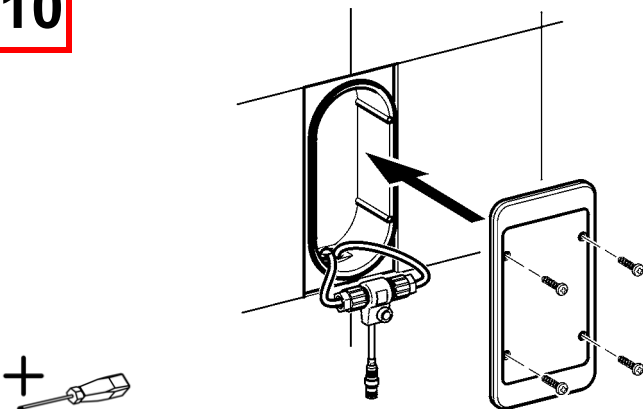

## 2. Ersatzteile

EN Replacement parts  
FR Pièces de rechange  
ES Piezas de recambio  
IT Pezzi di ricambio

NL Reserveonderdelen  
PL Części zamienne  
SV Reservdelar

CS Náhradní díly  
FI Varaosat  
RU Запчасти

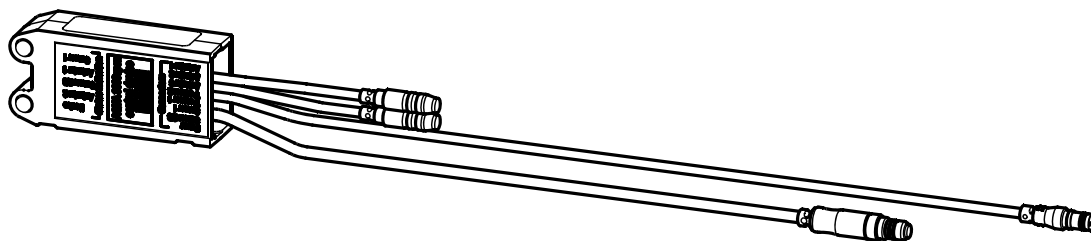

**ACEX1004: 2030059124**  
**ASEX1023**

**ACEM1002: 3600005784**  
**ASEX1051**

### 3. Zubehör I

EN Accessories I  
 FR Accessoire I  
 ES Accesorios I  
 IT Accessori I

NL Toebehoren I  
 PL Akcesoria I  
 SV Tillbehör I

CS Příslušenství I  
 FI Lisävarusteet I  
 RU принадлежности I

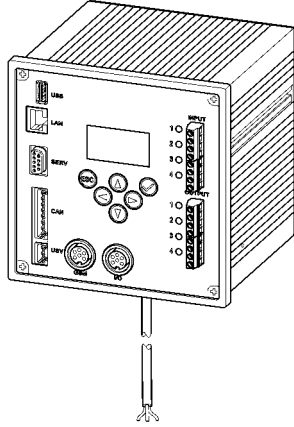

**2000108123  
 ZA3OP0011**

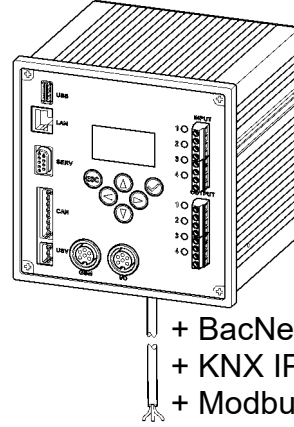

+ BacNet IP  
 + KNX IP  
 + Modbus IP  
**2030016282  
 ZA3OP0022**



IEC332-1

**100 m:  
 2000104272  
 ZAQUA011  
 25 m:  
 2000104274  
 ZAQUA012**

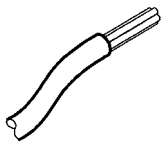

**100 m:  
 2000100801  
 ZAQUA077  
 25 m:  
 2000100852  
 ZAQUA078**

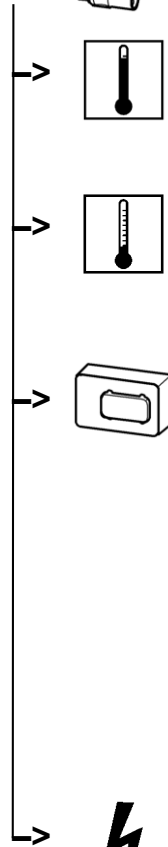
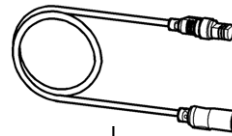

**1,5 m:  
 2000105709  
 ZA3OP0009**

**1,5 m:  
 2000105710  
 ZAQUA017**

**1 m:  
 2030041919  
 ACEX9006**

**2 m:  
 2030041920  
 ACEX9007**

**3 m:  
 2030056669  
 ACEX9013**



**5 m:  
 2000101055  
 ZAQUA073**

## 4. Zubehör II

EN Accessories II  
FR Accessoire II  
ES Accesorios II  
IT Accessori II

NL Toebehoren II  
PL Akcesoria II  
SV Tillbehör II

CS Příslušenství II  
FI Lisävarusteet II  
RU принадлежности II

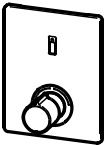
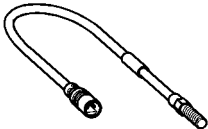
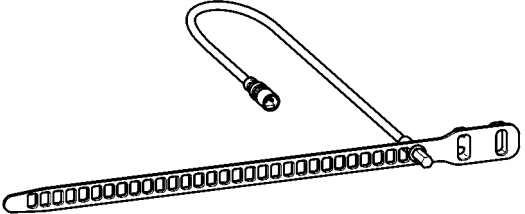
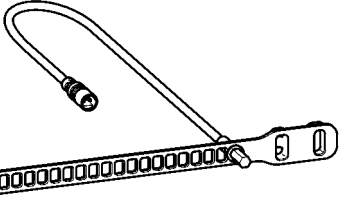
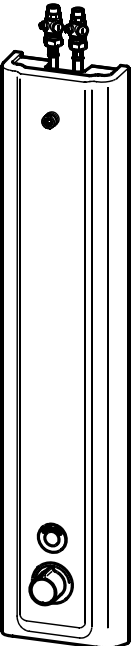
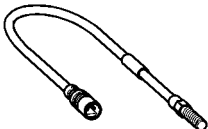
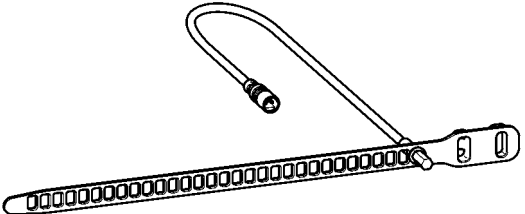
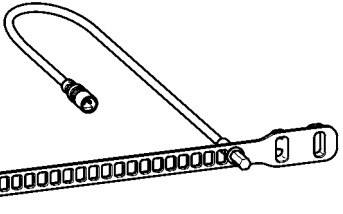
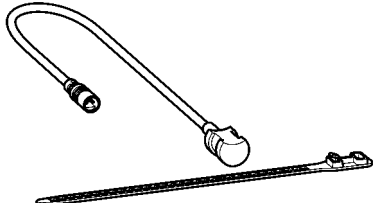
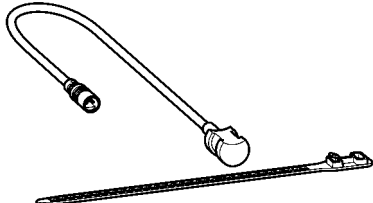
		
	 <b>2000100972</b> <b>ZAQUA017</b>	
	 <b>2000100973</b> <b>ZAQUA018</b>	 <b>2000100974</b> <b>ZAQUA019</b>
	 <b>2000100972</b> <b>ZAQUA017</b>	
	 <b>2000100973</b> <b>ZAQUA018</b>	 <b>2000100974</b> <b>ZAQUA019</b>
	 <b>2000100975</b> <b>ZAQUA020</b>	 <b>2000100976</b> <b>ZAQUA021</b>



## Notizen

---

EN Notes

FR Notes

ES Notas

IT Annotazioni

NL Notities

PL Uwagi

SV Notiser

CS Poznámky

FI Muistiinpanot

RU Примечания

## Notizen

---

EN Notes

FR Notes

ES Notas

IT Annotazioni

NL Notities

PL Uwagi

SV Notiser

CS Poznámky

FI Muistiinpanot

RU Примечания

## Notizen

---

EN Notes

FR Notes

ES Notas

IT Annotazioni

NL Notities

PL Uwagi

SV Notiser

CS Poznámky

FI Muistiinpanot

RU Примечания

**Australia**

PR Kitchen and  
Water Systems Pty Ltd  
Dandenong South VIC 3175  
Phone +61 3 9700 9100

**Austria**

KWC Austria GmbH  
6971 Hard, Austria  
Phone +43 5574 6735 0

**Belgium, Netherlands &  
Luxembourg**

KWC Aquarotter GmbH  
9320 Aalst; Belgium  
Phone NL +31 (0) 492 728 224  
BE/LU +32 (0) 53 60 31 50

**Czech Republic**

KWC Aquarotter GmbH  
14974 Ludwigsfelde, Germany  
Phone +49 3378 818 309

**France**

KWC Austria GmbH  
6971 Hard, Austria  
Phone +33 800 909 216

**Germany**

KWC Aquarotter GmbH  
14974 Ludwigsfelde  
Phone +49 3378 818 0

**Italy**

KWC Austria GmbH  
6971 Hard, Austria  
Numero Verde +39 800 789 233

**Middle East**

KWC ME LLC Ras Al Khaimah,  
United Arab Emirates  
Phone +971 7 2034 700

**Poland**

KWC Aquarotter GmbH  
14974 Ludwigsfelde, Germany  
Phone +48 58 35 19 700

**Spain**

KWC Austria GmbH  
6971 Hard, Austria  
Phone +43 5574 6735 211

**Switzerland & Liechtenstein**

KWC Group AG  
5726 Unterkulm, Switzerland  
Phone +41 62 768 69 00

**Turkey**

KWC ME LLC Ras Al Khaimah,  
United Arab Emirates  
Phone +971 7 2034 700

**United Kingdom**

KWC DVS Ltd - Northern Office  
Barlborough S43 4PZ  
Phone +44 1246 450 255

KWC DVS Ltd - Southern Office  
Paignton TQ4 7TW  
Phone +44 1803 529 021

**EAST EUROPE**

Bosnia Herzegovina  
Bulgaria | Croatia  
Hungary | Latvia  
Lithuania | Romania  
Russia | Serbia | Slovakia  
Slovenia | Ukraine

KWC Aquarotter GmbH  
14974 Ludwigsfelde, Germany  
Phone +49 3378 818 261

**SCANDINAVIA & ESTONIA**

Finland | Sweden | Norway  
Denmark | Estonia

KWC Nordics Oy  
76850 Naarajärvi, Finland  
Phone +358 15 34 111

**OTHER COUNTRIES**

**KWC Austria GmbH**  
**6971 Hard, Austria**  
**Phone +43 5574 6735 0**

